

XRLED 4000-W Framing

PR-8154

This product manual contains important information about the safe installation and use of this projector. Please read and follow these instructions carefully and keep this manual in a safe place for future reference.

PR LIGHTING LTD.
<http://www.pr-lighting.com>

INDEX

1	SAFETY AND WARNINGS.....	3
2	INSTRUCTIONS	4
3	APPEARANCE.....	5
4	INSTALLATION	6
5	SETUP AND CONFIGURATION.....	8
6	OPERATION MENU.....	11
7	DMX CHART	16
8	SIGNS ON THE TOUCH SCREEN.....	26
9	ERROR MESSAGES.....	26
10	TECHNICAL DATA.....	27
11	CIRCUIT DIAGRAM	32
12	COMPONENT ORDER CODES	33
13	LIGHTING FAN INSTALLATION POSITION.....	34

The following items are supplied with the projector and please check:

Name	Quantity	Unit	Remark
G clamp	2	Pcs	
XLR connector	1	Set	Male and female
Safety cord	2	Pcs	
User manual	0	Pc	QR code
Ω clamp	2	Pcs	Optional

Please note that as part of our ongoing commitment to continuous product development, specifications are subject to change without notice. Whilst every care is taken in the preparation of the manual we reserve the right to change specifications in the course of product improvement. The publishers cannot be held responsible for the accuracy of the information herein, or any consequence arising from them.

Every unit is tested completely and packed properly by the manufacturer. Please make sure the packing and / or the unit are in good condition before installation and use. Should there be any damage caused by transportation, consult your dealer and do not use the unit. Any damage caused by improper use will not be assumed by the manufacturer and / or dealer.

Any future technical changes are not subject to further notice.

Note: For the products made by Guangzhou PR lighting Ltd, the warranty for the whole product is one year starting from the delivery date but the light source is not within the warranty.







1. SAFETY AND WARNINGS



NOTE

Before a projector's installation, power-on, operation and maintenance, please carefully read the safety information hereinafter!

The following safety signs are used in the user manual.

						
Warning	User Manual	Electrical shock	Goggles	Protective Gloves	Flames	High Temperature



- When unpacking, check if there is transportation damage before using the projector. Should there be any damage caused by transportation, consult your dealer and do not use it.
- The manufacture is not responsible for loss caused by the user not following the manual or changing the projector as he/she likes.
- Please be noted that the damage caused by changing the projector at will is not warranted.
- Do not hesitate to contact the dealer or the manufacturer if any questions or advice.



- The projector is for indoor use only, IP20.
- Use only in dry locations. Keep this unit away from rain and moisture, excessive heat, humidity and dust. Do not allow contact with water or any other liquids.
- The projector should be kept away from high temperature, fire, electrical surge, vibration and strong light while being operated.
- The projector is only intended for installation, operation and maintenance by qualified personnel. And the operation must strictly follow the procedures in the manual.
- The projector is not for a user for any replacements and the user shouldn't open the projector for repair and maintenance.



- Don't look straightly into the light sources especially for epileptics, otherwise eyes will be burned. 
- Do not connect this device to any type of dimmer pack.
- If the lamp, lens and screen protective cover of the a lighting fixture have obvious damage, i.e., to the extent that it hurts the performance like cracking or deformation. Please stop use it and replace them with the original parts, otherwise its performance will be compromised.
- For the location of a lighting fixture, it shouldn't be seen in the distance of less than 4 meters.



- Before operation, please confirm that all covers(housing) are on and screws tightened. It's forbidden to use a projector while covers(housing)are off.
- Keep the lamp clean and do not touch it with bare hands.
- While operating it, wear protective items.



- Any electrical connection must be carried out by a qualified person.
- Before installation, please confirm the voltage supplied matches what is required for the projector.
- Each projector must be properly earthed and installed as per related electrical standards.
- Do not use power cord with its insulator damaged and connect the power cord with other cables.
- If the projector is not used or under cleaning,, please hold the plug and unplug it. Do not unplug it forcefully or by pulling the power cable.
- All power cords must conform to related safety and regulations.

- While being operated, the projector should not be under rains or in humidity.
- Do not switch on and off the projector constantly in very short intervals, otherwise the light source's and other electrical parts' life will be shortened .



- There are safety cord holes at the bottom of the base of a projector. In view of safety, please run the safety cord supplied through the safety cord holes for safety support.
- Before any installation, maintenance and cleaning work, please ensure the projector is disconnected from power mains.



- After stable operation under normal ambient temperature ,the temperature of the external surface of the housing of the LED lighting fixture (the surface of the heat sink) is 65°C after the stable running.
- While the lamp is stricken for the first time, there will be smoke and strange smell. It's normal and does not mean the projector has some defects.



- Do not touch the metallic housing of a projector to avoid being burnet.
- Do not mount the projector directly on inflammable surface.
- Do not project the beam straightly on combustibile items and the minimum distance between the projector and illuminated items is 10m.
- A projector should be installed with good ventilation and the minimum distance between the projector and walls is 50cm. At the same time, please ensure the fans and air inlets and outlets are workable.



- The product meets The General Technical Requirements and Standards for Recycle and Use Of Expired Appliance and Electronic Products.
- When the product meets disposal standards and needs to be disposed, a client needs to dispose and recycle it.

2. INSTRUCTIONS

•CLEANING AND MAINTENANCE

If a projector can't start. Please check if the fuse is blown up. If it does, replace it with a new fuse with same ratings. And the projector has over-temperature protective device. If the temperature is too high, the protective device will be triggered to shut the projector off. When it happens, please check if the fans run normally or fan shield is blocked by dust. After the issue is solved, restart the projector.

The accumulation of oil, smoke and dust on the lens will compromise the light output. Cleaning a projector is very necessary to ensure a reliable use of it. Cooling fans need to be cleaned every 15days. Internal lens, reflector and hot mirror need to be cleaned periodically to optimize light output.

Cleaning frequency is to be decided by operations and its environment. Use soft cloth and normal detergent for glass for cleaning work. It's advised external optical system be cleaned every 20days and internal optical systems every 30/60days. Keep lens clean and do not touch optical parts with bare hands.



- Before any maintenance and cleaning, please ensure the project is off the power.
- Only qualified person is allowed to do maintenance.
- During maintenance and before maintenance, the projector must be off power.



- To avoid sunlight or other light penetrating into the head via the front lens, resulting in high temperature internally causing damages to the projector. Before power-off, please use Tilt channel to move the head and make it facing downward.
- Do not use alcohol or other organic solvent to clean the housing to avoid damage.
- Do not use any solvent with chemical elements to clean color filters or hot mirror.

•LUBRICATION

To ensure smooth movement of gobos and zoom and focus lens, it's advised rotators' bearings and 2 sliding bars for zoom and focus lens be lubricated every 2 months. High quality and high temperature lubricant/grease is advised..

•TROUBLESHOOTING

PROBLEM	ACTION
The projector can't be switched on	<ul style="list-style-type: none"> ➤ Check if the fuse is burned ➤ Check if the power cord is connected well ➤ Check if the switching power supply is bad or not connected well. A professional technician is required for the repair ➤ Check if the control board is connected well. .A professional technician is required for the repair
The projector can be switched on , but the LED lamp's brightness can't be controlled	➤ Check if the LED driver board is connected well. A professional technician is required for the repair
The projector can be switched on normally, but not controlled by the DMX controller	<ul style="list-style-type: none"> ➤ Make sure that the fixture's start address is right ➤ Replace or repair the XLR signal cable.
The beam is not bright and its brightness decreases sharply	<ul style="list-style-type: none"> ➤ Make sure the fans are working well or fans and their shields are not blocked by dust. ➤ Make sure that the internal optics is clean.
The project image appears to have a halo	➤ Carefully clean the LED lamp, optical lenses and other components.
Heavily Defective Beam	<ul style="list-style-type: none"> ➤ Check if lens are in good condition(not cracked) ➤ Clean dust or grease on the lens.

3.APPEARANCE

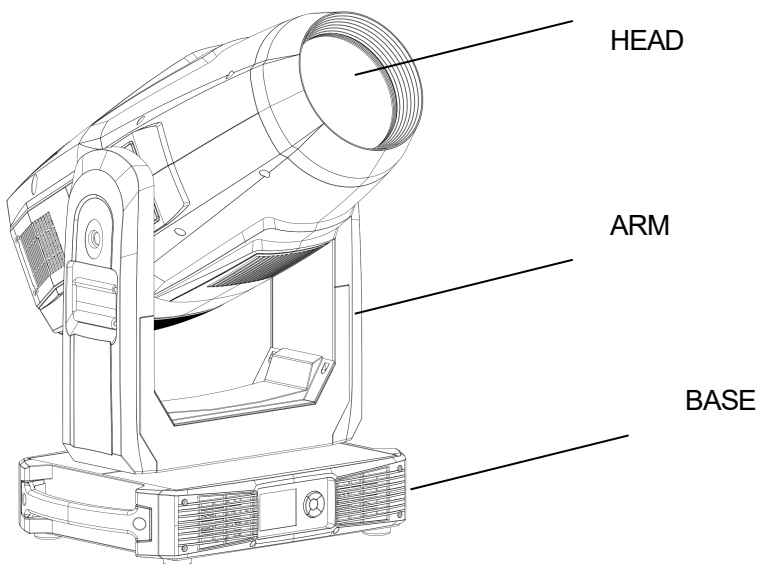

4. INSTALLATION

•RIGGING

During transportation, please lock the projector well; Before the use of projector please unlock the head. It's forbidden to run the projector without unlock Pan and Tilt

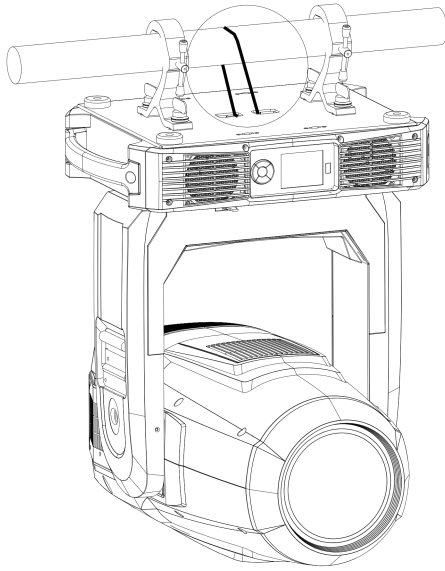

Safety cord

WARNING

Please run safety cord through the safety hole for safety.

Note:

1. the distance between the foot of the base and the front lens cover(the head facing downward)
2. the distance between mounting truss and the front lens cover(the head facing downward)
3. The maximum diameter of the rotating head (minimum spacing between fixtures)

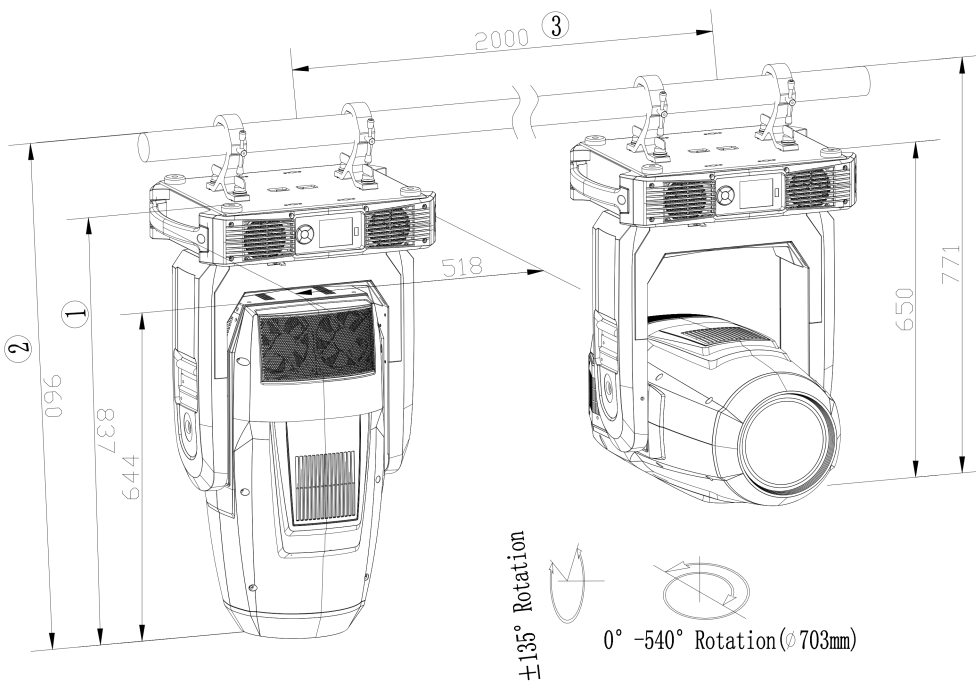

Take 2 clamps and 1 safety cords out from the package and mount 2 clamps on the underside of fixture with 4 retainers attached to each clamp. Hang the fixture on the structure and fasten the screws attached to each clamp. (See the **WARNING** on the underside of the base as shown above) Always ensure that the projector is firmly anchored to avoid vibration and slipping whilst functioning. Always ensure that the structure that you are going to mount the projector is secure and is strong enough to support the weight of the fixture.



WARNING:

- The projector **MUST** be lifted or carried by the **HANDLES** instead of clamps.
- For safety the safety cord should afford 10 times the Projector's weight.

• **POWER CONNECTIONS**

Connect the power cord as follows:

- L (live) =brown
- E (earth) =yellow/green
- N (neutral) =blue

Before power connection, please ensure the power supplied must match what the nameplate says. It is recommended that each projector be connected with power separately so that they may be individually switched on and off.



- The earth wire(yellow/green) must be connected to the ground. And electrical connection must be in accordance with the standards concerned.
- If any questions about the electrical installation, do not continue but consult a qualified electrician.

DMX CONTROL CONNECTION

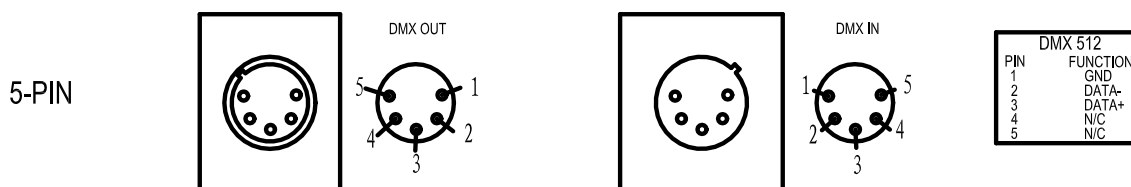

Connection between controller and projector and between one projector and another must be made with a twin-screened cable, with each wire having at least a 0.5mm in diameter. Connection to and from the projector is via cannon 5 pin (which are included with the projector) or 5 pin XLR plugs and sockets. The XLR's are connected as shown in the figure above.

Note: care should be taken to ensure that none of the pins touch the metallic body of the plug or each other. XLR plugs and sockets mustn't be connected in any way other than mentioned in the above figure. The projector accepts digital control signals in protocol DMX512 (1990).

Connect the controller's DMX output to the first fixture's DMX input, and connect the first fixture's DMX output to the second fixture's DMX input and connect the rest fixtures in the same way. Eventually connect the last fixture's DMX output to a DMX terminator as shown in the figure below.

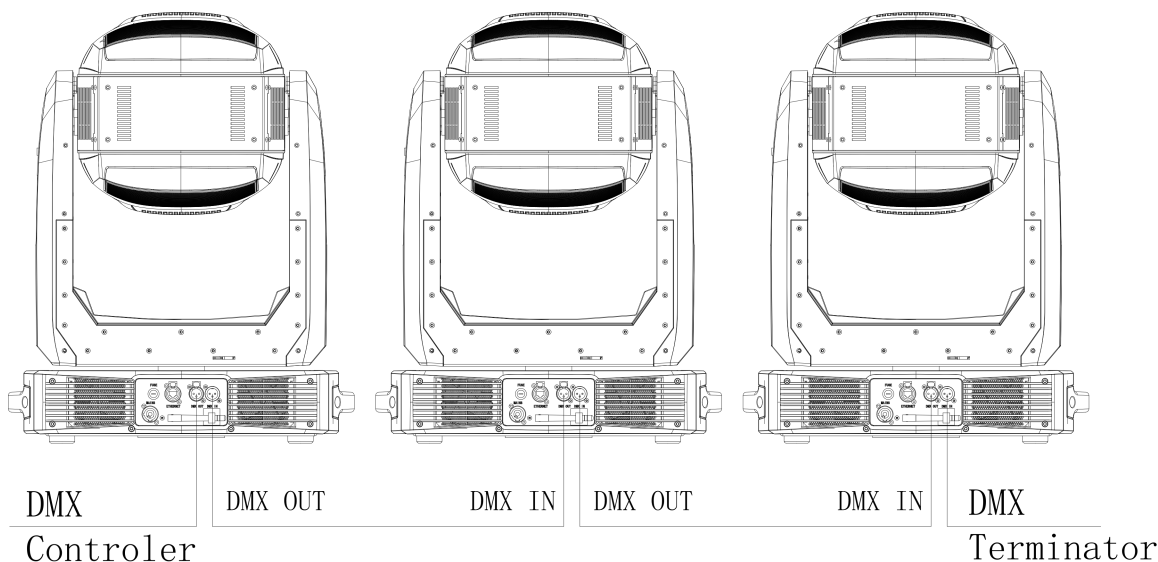

DMX TERMINATOR

In the Controller mode, at the last fixture in the chain, the DMX output has to be connected with a DMX terminator. This prevents electrical noise from disturbing and corrupting the DMX control signals.

The DMX terminator is simply an XLR connector with a 120Ω (ohm) resistor connected across pins 2 and 3, which is then plugged into the output socket on the last projector in the chain. The connections are illustrated below

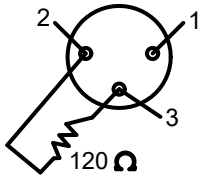

**DMX TERMINATOR
CONNECTION**

Connect a 120Ω(OHM) resistor across pins 2 and 3 in an XLR plug and insert into the DMX out socket on the last unit in the chain.

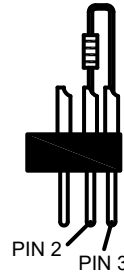

5. SETUP AND CONFIGURATION

•FRONT PANEL OPERATION



The configuration and start address can be set conveniently via push button and color touch screen.

To view or change its setup, touch any white area of the screen or push the key OK for more than 3 seconds to unlock the display(While only on battery, push OK key). After the unlocking, push ► key to enter into function menus. Each main menu has its submenus and each submenu has a specific function. For details, please see the “OPERATION MENU” with following the 6th point..

1. In the page of function setup, push any key of ◀, ▶, ▲ and ▼ or icon for the function desired.

2. At 2nd, 3rd and 4th level menus, key ◀ means ESCAPE, key ▶ won't function, key OK means ENTER. Push key OK to save any changes or enter into submenus. Push key ▲ or ▼ to change numbers(plus or minus) or tap any item required for changes.

Push the left key or shortcut key X to go back to the upper level menu. If none pushed, the system will go back to initial display automatically.

Shortcut keys: after the interface of FUNCTION MENU, the upper part is with menus for many functions. On the right, there are 4 shortcut keys, which are ←, →, lamp control or English/Chinese menus.

• DMX START ADDRESS

Each projector must be given a DMX start address so that the correct projector responds to the correct control signals. This DMX start address is the channel number from which the projector starts to “listen” to the digital control information being sent out from the controller. The projector has 3 DMX modes. There are short mode ,standard mode and extended mode. For example standard mode has 52 channels, so set the No. 1 projector's address 001, No. 2 projector's address 053, No. 3 projector's address 105, No. 4 projector's address 157, and so on.

Launch the projector. Press key OK more than 3seconds to unlock the display. After the unlocking, push key ► to enter into menus.

After selecting the sign of DMX setting, push OK key or tap the screen directly and select DMX address at 2nd level menus.

Push key ▲ or ▼ or tap sign < or > to set the number desired.

Push OK key to confirm.

Push key ◀ and it will return to the upper menu

.The DMX address can be set via RDM protocol if control panel is not convenient.

The projector has wireless control function with wireless receiver module and antenna for remote control.

The setup of it is below:

1. Enter into the projector's menu. Select the menu "Config Settings" via the keys of ▲ and ▼

2. Select **DMX control Mode--- Wireless First** (Note: Do not select **XLR ONLY**). The DMX wireless control function is activated.

Only after the projector is linked with a transmitter, can it receive wireless signal sent by the transmitter. If unlinking it, Press "Enter" for the menu of Unlink Wireless under the upper level menu of Config Settings.

•STAND-ALONE MODE

Operate the projector without connecting with a controller, enable the master mode through the operation panel, the projector will run in Stand-Alone mode automatically.
DMX address can be set at any number within 512.

•MASTER/SLAVE MODE

Many projectors can run synchronously in the Master/Slave mode by linking them with each other. First, connect the first fixture's DMX output to the second fixture's DMX input using XLR-XLR control cable and then connect the second fixture's DMX output to the third fixture's DMX input, and so on until all projector are connected in this way. Eventually connect the last fixture's DMX output to a DMX terminator. Set 1st projector as the master and others are Slaves.

Start Addresses of all Slaves are 001; Operation mode of the Master can be set any mode for a Master' and Slaves' operation mode can be set accordingly.

After Powered on, the group will run in Master/Slave Mode(It is advised the number of projectors in a DMX chain is 32 at maximum)

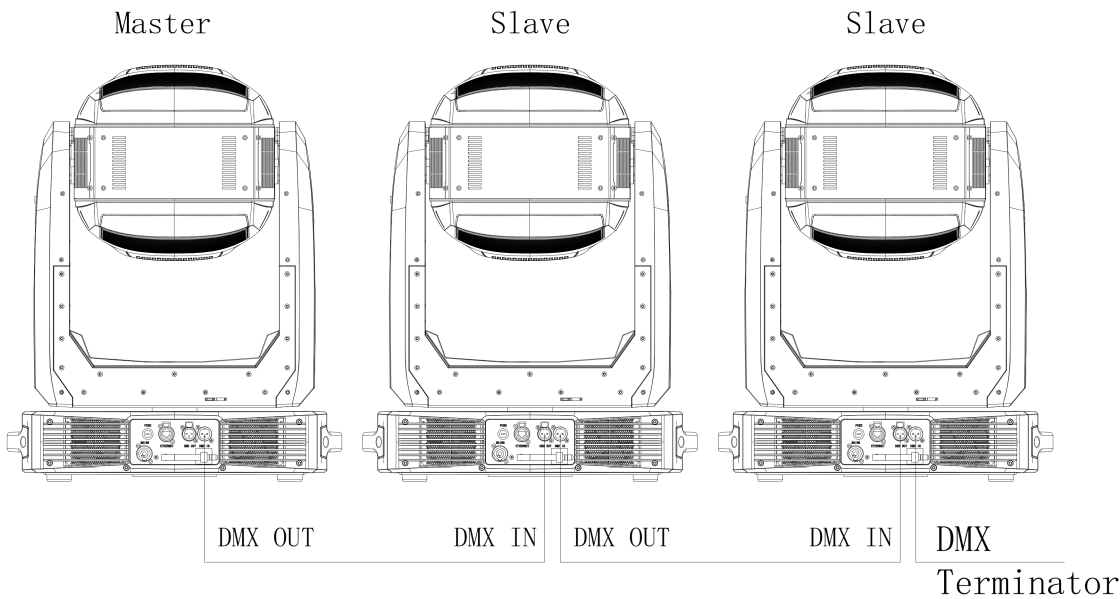

•TO SET UP COLOR TEMPERATURE AND COLOR MACRO

A projector has 7 color temperature macros and 89 standard color macros. Color temperatures are for respective 2700K,3000K,3500K,4000K,4500K,5000K and 5700K. Under the DMX channel of CMY macro, color macro and its color temperature macro can be selected.

•TO SET UP DIMMER CURVE AND LED REFRESH FREQUENCY

A projector has 5 gamma dimmer curves: gamma 2.0, gamma 2.2, gamma 2.4 , gamma 2.6 and straight line.

It has 8 LED refresh frequency: LED refresh frequency 1200Hz, LED refresh frequency 2400Hz, LED refresh frequency 4800Hz, LED refresh frequency 10000Hz, LED refresh frequency 12000Hz, LED refresh frequency 15000Hz, LED refresh frequency 20000Hz and LED refresh frequency 25000Hz.

It has fast, medium and slow dimmer speeds.

Its setups are as follows:

1. Hold the **OK** button for more than 3s to unlock the control panel and then push **▶** button to enter into the menus and select “Option Settings”.
2. Select “Dimmer Settings” and select any mode of gamma curve /LED frequency /dimmer speed for adjustment.

•FAN SPEED MODES

It has standard and theater modes. Theater mode is quiet mode.

Its setups are as follows:

1. Hold the **OK** button for more than 3s to unlock the control panel and then push **▶** button to enter into the menus and select “Option Settings”.
2. Select either of Standard and theater modes after the menu of Fan Settings.

•PROJECTOR TYPE

It has 3 modes of moving head light, fixed focus profile light and zoom profile light.

For moving head light: linear zoom 6°-54°, standard fan mode ;

For fixed focus profile light, it has 6 beam angles: 6°、10°、19°、26°、36°、54°. After the beam angle selected, zoom lens can't move and the light spot can be focused via focus lens;

For zoom profile light, it has 3 beam angle ranges: 6-15°、15-35°、35-54°. If the beam angle range selected, zoom lens can move in the exact range accordingly and the light spot be focused via focus lens.

For fixed focus profile light and zoom profile light, it can enter into quiet theater mode automatically.

The setups are as follows:

1. Hold **OK** key for more than 3s to unlock control panel. After unlocking the control panel, push **▶** button to enter into operation menus and select “Options Settings”
2. Select the projector type after entering into the menu of “Light Type”

•AUTO-FOCUS SETUP

A projector has auto-focus function for the distance ranges of 5m,10m,15m and 20m respectively. While any of Iris, Framing Blade, Fixed gobo wheel and Rotating Gobo Wheel is in use, Auto-Focus channel for specified distance can automatically focus the image. Then use Auto-Focus Calibration channel to fine tune the focused image. Priority sequence: Rotating gobo wheel>Fixed gobo wheel>Iris>Framing blades

•BRIGHTNESS CALIBRATION

For brightness calibration function, a controller can be used on the projectors in a DMX chain or a projector be done individually. After running for some time, the projectors need to be recalibrated in brightness for conformity with the help of LED brightness calibration channel via controller. The function has the following characteristics:

1. LED brightness calibration channel has 50 levels for adjustment with each level meaning power consumption decreases by 1%.
2. Calibration can be done on projectors in a DMX chain or a single one. After calibration done on a lot of projectors in a DMX chain, it can be done individually also if needed.
3. To avoid erroneous operation, after the fader of a DMX controller is at proper place for LED BRIGHTNESS CALIBRATION channel, the fader for channel of LED BRIGHTNESS CALIBRATION CONFIRMATION channel should be at right DMX value range to save parameters. The calibration is completed after the desired parameters are stored into the projectors.

•CRI MODE

It has HIGH CRI MODE and select it via DMX controller to activate it. The mode ensures high CRI optical effect.

6.OPERATION MENU

1st LEVEL	2nd LEVEL	3rd LEVEL	4th LEVEL	5th LEVEL
Address	DMX Address	1-466 (Short Mode) 1-461 (Standard Mode) 1-446 (Extended Mode)		
	IP Address	Default IP Address	2.X.X.X/10.X.X.X	
		Custom IP Address	X.X.X.X	
	SubNet Mask	X.X.X.X		
	ArtNet ArtNet Universe	0-255		
sACN Universe	1-63999			
Reset	Total Reset	Really Reset?	Confirm/ Cancel	
	Pan&Tilt Reset	Really Reset?	Confirm/ Cancel	
	Colour System Reset	Really Reset?	Confirm/ Cancel	
	Gobo Reset	Really Reset?	Confirm/ Cancel	
	Zo.Fo.Fr.Pr. Reset	Really Reset?	Confirm/ Cancel	
	Other Reset	Really Reset?	Confirm/ Cancel	
Config Settings	DMX Channel Mode	Short Mode 47CH		
		Standard Mode 52CH		
		Extended Mode 67CH		
		View Selected Mode	Strobe	
	Signal Select	XLR Only		
		XLR First		
		Wireless Only		
		Wireless First		
		Wireless In/XLR Out		
		Artnet Only		
		Artnet In/XLR Out		
		sACN Only		
	Loss of DMX	Normal time out		
		Hold last Value		
	Display Config	Display Mode	Off/After Delay	
			On Always	
		Display Invert	Invert OFF	
			Invert ON	
			Invert Auto	
		Language Setting	English	
	Chinese			
	Touch Screen Calibration	XXX		
	Temperature Unit	Celsius Degree		
Fahrenheit Degree				
Un-Link Wireless	Really Un-Link?	Confirm/ Cancel		
Defaults	Restore Defaults?	Confirm/ Cancel		
Option Settings	Pan/Tilt Settings	Pan DMX Invert	OFF/ ON	
		Tilt DMX Invert	OFF/ ON	
		Pan Tilt Swap	OFF/ ON	
		XY Feedback	OFF/ ON	

		Pan/Tilt mode	Speed/Time	
	Dimmer Settings	Gamma Curve	Gamma 2.0/2.2/2.4/2.6/straight line	
		LED Refresh Rate	1200/2400/4800/10000/12000/15000/20000/25000Hz	
		Dimmer Speed	Fast/Medium/Slow Speed	
	Fan Settings	Standard/Theatre		
	Light Type	Moving Head 6-54		
		Profile 35-54		
		Profile 15-35		
		Profile 6-15		
		Profile 54		
		Profile 36		
		Profile 26		
		Profile 19		
		Profile 10		
	Profile 6			
	Invert Settings	Iris Invert	OFF/ ON	Invert Settings
		Zoom Invert	OFF/ ON	
		CYM Invert	OFF/ ON	
		CTO Invert	OFF/ ON	
	Defaults	Restore Defaults?	Confirm/ Cancel	
Information	View DMX Values	Channel Value Strobe XXX Dimmer XXX Dimmer Fine XXX CMY Macro XXX Cyan XXX Yellow XXX Magenta XXX CTO XXX Color Wheel1 XXX Color Wheel1 Fine XXX Color Wheel21 XXX Color Wheel12 Fine XXX Iris XXX Iris macro XXX Fixed gobo wheel XXX Ro. Gobo wheel XXX Gobo Rota. XXX Gobo Rota. Fine XXX Blade 1 Left XXX Blade 1 Right XXX Blade 2Left XXX Blade 2 Right XXX Blade3Left XXX Blade 3Right XXX Blade4 Left XXX Blade 4 Right XXX Framing module R. XXX Framing Module R.F. XXX Prism 1 XXX Prism 1 Rotation XXX Prism 2 XXX Prism 2 Rotation XXX Effect Wheel XXX Effect Wheel Ro. XXX Frost 1 XXX Frost 2 XXX Focus XXX Zoom XXX		

	Auto Focus XXX Auto Focus Calibration XXX Pan XXX Pan Fine XXX Tilt XXX Tilt Fine XXX Pan and Tilt Speed XXX CRI mode XXX Power/Special Fun. XXX Product Type XXX LED Dimmer Calibration XXX Calibration confirm XXX Reserve 1 XXX Reserve 2 XXX		
Lamp Hours	Reset Lamp Hours		
Total Hours			
Temperature	Display Board XX°C/F		
	Pan and Tilt Board XX°C/F		
	Driver Board 1 XX°C/F		
	Driver Board 2 XX°C/F		
	Driver Board 3 XX°C/F		
	Driver Board 4 XX°C/F		
	Blade Board XX°C/F		
	Fan Board XX°C/F		
	LED XX°C/F LED Sensor XX°C/F		
Software Version	Display Board	System= XXX Boot =XXX	
	Pan and Tilt Board	System= XXX Boot =XXX	
	Driver Board 1	System= XXX Boot =XXX	
	Driver Board 2	System= XXX Boot =XXX	
	Driver Board 3	System= XXX Boot =XXX	
	Driver Board4	System= XXX Boot =XXX	
	Blade Board	System= XXX Boot =XXX	
	Fan Board	System= XXX Boot =XXX	
Electronic SN	Electronic SN= *****		
RDM Device Label	RDM Device Label ANSI E1.20 RDM		
Fan status	Fan Speed Status Base Fan1 XXX XXX Base Fan2 XXX XXX Gobo Fan XXX XXX Framing Fan1 XXX XXX Framing Fan2 XXX XXX Prism Fan XXX XXX LED Fan1 XXX XXX LED Fan2 XXX XXX LED Fan3 XXX XXX LED Fan4 XXX XXX		

		LED.D Fan1 XXX XXX		
		LED.D Fan2 XXX XXX		
Service	Manual Effect Control	Channel Value		
		Strobe XXX		
		Dimmer XXX		
		Dimmer Fine XXX		
		CMY Macro XXX		
		Cyan XXX		
		Yellow XXX		
		Magenta XXX		
		CTO XXX		
		Color Wheel1 XXX		
		Color Wheel1 Fine XXX		
		Color Wheel21 XXX		
		Color Wheel2 Fine XXX		
		Iris XXX		
		Iris macro XXX		
		Fixed gobo wheel XXX		
		Ro. Gobo wheel XXX		
		Gobo Rota. XXX		
		Gobo Rota. Fine XXX		
		Blade 1 Left XXX		
		Blade 1 Right XXX		
		Blade 2Left XXX		
		Blade 2 Right XXX		
		Blade3Left XXX		
		Blade 3Right XXX		
		Blade4 Left XXX		
		Blade 4 Right XXX		
		Framing module R. XXX		
		Framing Module R.F. XXX		
		Prism 1 XXX		
		Prism 1 Rotation XXX		
		Prism 2 XXX		
		Prism 2 Rotation XXX		
Effect Wheel XXX				
Effect Wheel Ro. XXX				
Frost 1 XXX				
Frost 2 XXX				
Focus XXX				
Zoom XXX				
Auto Focus XXX				
Auto Focus Calibration XXX				
Pan XXX				
Pan Fine XXX				
Tilt XXX				
Tilt Fine XXX				
Pan and Tilt Speed XXX				
CRI Mode XXX				
	Factory Test			
Operation Mode	DMX Mode	Change Operation Mode?	Confirm/ Cancel	
	Master Mode	Preset Memory	Change Operation Mode?	Confirm/ Cancel
		User Memory 1	Change Operation Mode?	
		User Memory 2	Change Operation Mode?	
	Stand-Alone Mode	Preset Memory	Change Operation Mode?	
		User Memory 1	Change Operation Mode?	
		User Memory 2	Change Operation Mode?	
Static Scene	Change Operation Mode?			
User Memories	Edit User Memory	Edit User Memory 1 / Edit User Memory 2	Scene XX (1~200 Scenes)	Strobe XXX Dimmer XXX Dimmer Fine XXX CMY Macro XXX Cyan XXX Yellow XXX Magenta XXX

			CTO XXX Color Wheel1 XXX Color Wheel1 Fine XXX Color Wheel21 XXX Color Wheel2 Fine XXX Iris XXX Iris macro XXX Fixed gobo wheel XXX Ro. Gobo wheel XXX Gobo Rota. XXX Gobo Rota. Fine XXX Blade 1 Left XXX Blade 1 Right XXX Blade 2Left XXX Blade 2 Right XXX Blade3Left XXX Blade 3Right XXX Blade4 Left XXX Blade 4 Right XXX Framing module R. XXX Framing Module R.F. XXX Prism 1 XXX Prism 1 Rotation XXX Prism 2 XXX Prism 2 Rotation XXX Effect Wheel XXX Effect Wheel Ro. XXX Frost 1 XXX Frost 2 XXX Focus XXX Zoom XXX Auto Focus XXX Auto Focus Calibration XXX Pan XXX Pan Fine XXX Tilt XXX Tilt Fine XXX Pan and Tilt Speed XXX CRI Mode XXX Fade Time XXX Hold Time XXX Delay MS/S/MIN Next scene XXX
		Edit Static Scene	Strobe XXX Dimmer XXX Dimmer Fine XXX CMY Macro XXX Cyan XXX Yellow XXX Magenta XXX CTO XXX Color Wheel1 XXX Color Wheel1 Fine XXX Color Wheel21 XXX Color Wheel2 Fine XXX Iris XXX Iris macro XXX Fixed gobo wheel XXX Ro. Gobo wheel XXX Gobo Rota. XXX Gobo Rota. Fine XXX Blade 1 Left XXX Blade 1 Right XXX Blade 2Left XXX Blade 2 Right XXX Blade3Left XXX Blade 3Right XXX Blade4 Left XXX Blade 4 Right XXX Framing module R. XXX

			Framing Module R.F. XXX Prism 1 XXX Prism 1 Rotation XXX Prism 2 XXX Prism 2 Rotation XXX Effect Wheel XXX Effect Wheel Ro. XXX Frost 1 XXX Frost 2 XXX Focus XXX Zoom XXX Auto Focus XXX Auto Focus Calibration XXX Pan XXX Pan Fine XXX Tilt XXX Tilt Fine XXX Pan and Tilt Speed XXX CRI Mode XXX	
	Init User Memory	Reset User Memory 1	Reset User Memory?	Input Password 123
		Reset User Memory 2	Reset User Memory?	Input Password 123
		Reset Static Scene	Reset Static Scene?	Input Password 123

7.DMX CHART

Short mode	Standard mode	Extended mode	Function Description	Decimal Low	Decimal High
1	1	1	Strobe		
			Close	0	
			Pulse strobe speed from slow to fast	1	127
			Strobe speed slow to fast	128	255
2	2	2	Dimmer		
			Close	0	0
			Non-linear dimmer from dark to light (0-100%)	1	255
	3	3	Dimmer Fine		
			Dimmer in 16 bit	0	255
3	4	4	CYM Macro		
			The following functions will disable CMY ,CTO		
			No function	0	7
			Color Temperature 2700K	8	9
			Color Temperature 3000K	10	11
			Color Temperature 3500K	12	13
			Color Temperature 4000K	14	15
			Color Temperature 4500K	16	17
			Color Temperature 5000K	18	19
			Color Temperature 5700K	20	21
			Color Macro1	22	23
			Color Macro2	24	25
			Color Macro3	26	27
			Color Macro4	28	29
Color Macro5	30	31			

Color Macro6	32	33
Color Macro7	34	35
Color Macro8	36	37
Color Macro9	38	39
Color Macro10	40	41
Color Macro11	42	43
Color Macro12	44	45
Color Macro13	46	47
Color Macro14	48	49
Color Macro15	50	51
Color Macro16	52	53
Color Macro17	54	55
Color Macro18	56	57
Color Macro19	58	59
Color Macro20	60	61
Color Macro21	62	63
Color Macro22	64	65
Color Macro23	66	67
LEE 4 (Medium Bastard Amber)	68	69
LEE 10 (Medium Yellow)	70	71
LEE 19 (Fire)	72	73
LEE 26 (Bright Red)	74	75
LEE 58 (Lavender)	76	77
LEE 68 (Sky Blue)	78	79
LEE 71 (Tokyo Blue)	80	81
LEE 79 (Just Blue)	82	83
LEE 88 (Lime Green)	84	85
LEE 90 (Dark Yellow Green)	86	87
LEE 100 (Spring Yellow)	88	89
LEE 101 (Yellow)	90	91
LEE 102 (Light Amber)	92	93
LEE 103 (Straw)	94	95
Lee 104 (Deep Amber)	96	97
LEE 105 (Orange)	98	99
LEE 106 (Primary Red)	100	101
LEE 111 (Dark Pink)	102	103
LEE 115 (Peacock Blue)	104	105
LEE 116 (Medium Blue-Green)	106	107
LEE 117 (Steel Blue)	108	109
LEE 118 (Light Blue)	110	111
LEE 119 (Deep Blue)	112	113
LEE 120 (Dark Blue)	114	115
LEE 121 (LEE Green)	116	117

			LEE 128 (Bright Pink)	118	119
			LEE 131 (Marine Blue)	120	121
			LEE 132 (Medium Blue)	122	123
			LEE 134 (Golden Amber)	124	125
			LEE 135 (Deep Golden Amber)	126	127
			LEE 136 (Pale Lavender)	128	129
			LEE 137 (Special Lavender)	130	131
			LEE 138 (Pale Green)	132	133
			LEE 139 (Primary Green)	134	135
			LEE 141 (Bright Blue)	136	137
			LEE 147 (Apricot)	138	139
			LEE 148 (Bright Rose)	140	141
			LEE 152 (Pale Gold)	142	143
			LEE 154 (Pale Rose)	144	145
			LEE 157 (Pink)	146	147
			LEE 158 (Deep Orange)	148	149
			LEE 162 (Bastard Amber)	150	151
			LEE 164 (Flame Red)	152	153
			LEE 165 (Daylight Blue)	154	155
			LEE 169 (Lilac Tint)	156	157
			LEE 170 (Deep Lavender)	158	159
			LEE 172 (Lagoon Blue)	160	161
			LEE 179 (Chrome Orange)	162	163
			LEE 180 (Dark Lavender)	164	165
			LEE 181 (Congo Blue)	166	167
			LEE 197 (Alice Blue)	168	169
			LEE 201 (Full C.T. Blue)	170	171
			LEE 202 (Half C.T. Blue)	172	173
			LEE 203 (Quarter C.T. Blue)	174	175
			LEE 204 (Full C.T. Orange)	176	177
			LEE 205 (Half C.T. Orange)	178	179
			LEE 206 (Quarter C.T. Orange)	180	181
			LEE 247 (LEE Minus Green)	182	183
			LEE 248 (Half Minus Green)	184	185
			LEE 281 (Three Quarter C.T. Blue)	186	187
			LEE 285 (Three Quarter C.T. Orange)	188	189
			LEE 352 (Glacier Blue)	190	191
			LEE 353 (Lighter Blue)	192	193
			LEE 715 (Cabana Blue)	194	195
			LEE 778 (Millennium Gold)	196	197
			LEE 793 (Vanity Fair)	198	199
			CMY colour mixing from slow to fast	200	255
4	5	5	Cyan		

			Cyan (Linear 0-100%)	0	255
		6	Cyan Fine		
			Cyan in 16 Bit precision	0	255
5	6	7	Yellow		
			Yellow (Linear 0-100%)	0	255
		8	Yellow Fine		
			Yellow in 16 Bit precision	0	255
6	7	9	Magenta		
			Magenta (Linear 0-100%)	0	255
		10	Magenta Fine		
			Magenta in 16 Bit precision	0	255
7	8	11	CTO		
			Linear adjust from high to low	0	255
		12	CTO Fine		
			CTO in 16 Bit precision	0	255
8	9	13	Colour Wheel 1		
			Continual positioning		
			index 0-360°	0	63
			positioning		
			Open	64	67
			Open/Color1(Red)	68	71
			Color1(Red)	72	75
			Color1(Red)/Color 2(Green)	76	79
			Color 2(Green)	80	83
			Color 2(Green)/Color 3(Blue)	84	87
			Color 3(Blue)	88	91
			Color 3(Blue)/ Color 4(Orange)	92	95
			Color 4(Orange)	96	99
			Color 4(Orange)/Color 5(Pink)	100	103
			Color 5(Pink)	104	107
			Color 5 (Pink) /Color 6 (Light cyan)	108	111
			Color 6(Light cyan)	112	115
			Color6(Light cyan)/ Open	116	119
			Open	120	127
			Clockwise rainbow effect rotation speed from slow to fast	128	191
Anti-clockwise rainbow effect rotation speed from slow to fast	192	255			
	10	14	Color Wheel 1 Fine		
			Color Continual positioning in 16 Bit precision	0	255
9	11	15	Colour Wheel2		
			Continual positioning		
			index 0-360°	0	63
			positioning		
			Open	64	67

			Open/Color1(Deep Red)	68	71
			Color1(Deep Red)	72	75
			Color1(Deep Red)/Color 2(Amber)	76	79
			Color 2(Amber)	80	83
			Color 2(Amber)/Color 3(Tea red)	84	87
			Color 3(Tea red)	88	91
			Color 3(Tea red)/ Color 4(Apple Green)	92	95
			Color 4(Apple Green)	96	99
			Color 4(Apple Green)/Color 5(Dark magenta)	100	103
			Color 5(Dark magenta)	104	107
			Color 5 (Dark magenta) /Color 6 (UV)	108	111
			Color 6(UV)	112	115
			Color6(UV)/ Open	116	119
			Open	120	127
			Clockwise rainbow effect rotation speed from slow to fast	128	191
			Anti-clockwise rainbow effect rotation speed from slow to fast	192	255
	12	16	Color Wheel 2 Fine		
			Color Continual positioning in 16 Bit precision	0	255
10	13	17	Iris		
			Linear Iris from small to big 0-100%	0	255
		18	Iris in 16 bit		
			Iris in 16 bit precision	0	255
11	14	19	Iris Macro		
			Iris Macro disabled	0	10
			Iris Macro 1: from big to small with speed from slow to fast	11	74
			Iris Macro2: from small to big with speed from slow to fast	75	138
			Iris Macro3: Iris contracts from slow to fast	139	202
			Iris Macro4(Macro1 at random) with speed from slow to fast	203	210
			Iris Macro5(Macro2 at random) with speed from slow to fast	211	218
			Iris Macro6(Macro3 at random) with speed from slow to fast	219	226
			Open	227	255
12	15	20	Fixed gobo wheel		
			Open	0	15
			Gobo1	16	31
			Gobo2	32	47
			Gobo3	48	63
			Gobo4	64	79
			Gobo5	80	95
			Gobo6	96	111
			Gobo7	112	127
			Clockwise rotation from slow to fast	128	149
			Anti-clockwise rotation from slow to fast	150	171
			Gobo1 shake from slow to fast	172	183

			Gobo2 shake from slow to fast	184	195
			Gobo3 shake from slow to fast	196	207
			Gobo4 shake from slow to fast	208	219
			Gobo5 shake from slow to fast	220	231
			Gobo6 shake from slow to fast	232	243
			Gobo7 shake from slow to fast	244	255
13	16	21	Rotating gobo wheel		
			Open	0	31
			Gobo1	32	47
			Gobo2	48	63
			Gobo3	64	79
			Gobo4	80	95
			Gobo5	96	111
			Gobo6	112	127
			Clockwise rotation from slow to fast	128	143
			Anti-clockwise rotation from slow to fast	144	159
			Gobo1 shake from slow to fast	160	175
			Gobo2 shake from slow to fast	176	191
			Gobo3 shake from slow to fast	192	207
			Gobo4 shake from slow to fast	208	223
			Gobo5 shake from slow to fast	224	239
Gobo6 shake from slow to fast	240	255			
14	17	22	Rotating gobo wheel rotation		
			Indexing 0-360°	0	128
			Clockwise rotation from slow to fast	129	188
			Stop	189	195
			Anti-clockwise rotation from slow to fast	196	255
	18	23	Rotating gobo wheel rotation in 16 bit		
Rotating gobo wheel fine rotation			0	255	
15	19	24	Framing blade 1 left		
			Framing blade 1 left linearly closing from big to small	0	255
		25	Framing blade 1 left in 16 bit		
			Framing blade 1 left fine adjustment	0	255
16	20	26	Framing blade 1 right		
			Framing blade 1 right linearly closing from big to small	0	255
		27	Framing blade 1 right in 16 bit		
			Framing blade 1 right fine adjustment	0	255
17	21	28	Framing blade 2 left		
			Framing blade2 left linearly closing from big to small	0	255
		29	Framing blade 2 left in 16 bit		
			Framing blade 2 left fine adjustment	0	255
18	22	30	Framing blade 2 right		
			Framing blade 2 right linearly closing from big to small	0	255

		31	Framing blade 2 right in 16 bit		
			Framing blade 2 right fine adjustment	0	255
19	23	32	Framing blade 3 left		
			Framing blade 3left linearly closing from big to small	0	255
		33	Framing blade 3 left in 16 bit		
			Framing blade 3 left fine adjustment	0	255
20	24	34	Framing blade 3 right		
			Framing blade 3 right linearly closing from big to small	0	255
		35	Framing blade 3right in 16 bit		
			Framing blade 3right fine adjustment	0	255
21	25	36	Framing blade 4 left		
			Framing blade 4left linearly closing from big to small	0	255
		37	Framing blade 4left in 16 bit		
			Framing blade 4 left fine adjustment	0	255
22	26	38	Framing blade 4 right		
			Framing blade 4 right linearly closing from big to small	0	255
		39	Framing blade 4right in 16 bit		
			Framing blade 4right fine adjustment	0	255
23	27	40	Framing module rotation		
			Framing module indexing(0-360degrees)	0	127
			Stop	128	
			Framing module clockwise rotation from slow to fast	129	188
			Stop	189	195
			Framing module anti-clockwise rotation from slow to fast	196	255
	28	41	Framing module rotation in 16 bit		
			Framing module fine rotation	0	255
24	29	42	Prism1		
			No Prism	0	16
			Prism	17	255
25	30	43	Prism1 rotation		
			Prism index	0	127
			Prism stops	128	
			Rotation speed from slow to fast	129	191
			Stop rotating	192	
			Reverse rotation speed from slow to fast	193	255
26	31	44	Prism2		
			No Prism	0	16
			Prism	17	255
27	32	45	Prism2 rotation		
			Prism index	0	127
			Prism stops	128	
			Rotation speed from slow to fast	129	191
			Stop rotating	192	

			Reverse rotation speed from slow to fast	193	255
28	33	46	Effect Wheel		
			No effect wheel	0	19
			Effect wheel in	20	255
29	34	47	Effect Wheel Rotation		
			Clockwise rotation from slow to fast	0	127
			Anti-clockwise reverse rotation from slow to fast	128	255
30	35	48	Frost1		
			Light Frost from 0% to 100%	0	255
31	36	49	Frost2		
			Light Frost from 0% to 100%	0	255
32	37	50	Focus		
			Linearly focusing	0	255
		51	Focus Fine		
			Focus in 16 precision	0	255
33	38	52	Zoom		
			Linearly zooming	0	255
		53	Zoom Fine		
			Zoom in 16 Bit precision	0	255
34	39	54	Autofocus		
			While channels for Iris, Rotating Gobo Wheel and Rotating Gobo Wheel are in use, the projector has automatic focus function at some distance. Use "Autofocus Calibrations" channel (35/40/55) to focus the image. Priority: Rotating Gobo Wheel > Fixed Gobo Wheel > Iris > Framing module		
			The following functions will disable the focus channel (32/37/50) is disabled.		
			Autofocus Off	0	19
			Autofocus for 5M	20	39
			Autofocus for 10M	40	59
			Autofocus for 15M	60	79
Autofocus for 20M	80	255			
35	40	55	Autofocus Calibrations		
			focus calibrations up	0	127
			focus calibrations down	128	255
36	41	56	Pan		
			Pan movement	0	255
37	42	57	Pan Fine		
			Pan movement in 16 bit precision	0	255
38	43	58	Tilt		
			Tilt movement	0	255
39	44	59	Tilt fine		
			Tilt movement 16 bit precision	0	255

40	45	60	Pan/Tilt speed				
			Fast Speed Mode	0	1		
			Pan &Tilt speed from fast to slow	2	255		
41	46	61	CRI MODE				
			Normal mode	0	127		
			High CRI mode	128	255		
42	47	62	Power/Special functions				
			No function:	0	4		
			Reserved	5	19		
			To activate following functions, stay in DMX value for at least 5 s				
			Graphic display On	20	24		
			Graphic display Off	25	29		
			Reserved	30	44		
			Reserved	45	46		
			Fan standard mode	47	48		
			Fan theater mode	49	50		
			Fast speed dimmer	51	52		
			Mid speed dimmer	53	54		
			Slow speed dimmer	55	56		
			Gamma curve 2.0	57	58		
			Gamma curve 2.2	59	60		
			Gamma curve 2.4	61	62		
			Gamma curve 2.6	63	64		
			Straight line	65	66		
			LED refresh rate 1200Hz	67	68		
			LED refresh rate 2400Hz	69	70		
			LED refresh rate 4800Hz	71	72		
			LED refresh rate 10000Hz	73	74		
			LED refresh rate 12000Hz	75	76		
			LED refresh rate 1500Hz	77	78		
			LED refresh rate 20000Hz	79	80		
			LED refresh rate 25000Hz	81	82		
			Reserved	83	89		
			Pan/Tilt speed mode	90	94		
			Pan/Tilt time mode	95	99		
			Reserved	100	129		
			Reserved	130	139		
			Pan/Tilt reset	140	149		
			Colour system reset	150	159		
Gobo wheels reset	160	169					
Reserved	170	179					
Zoom/focus/frost/prism reset	180	189					
Others(Iris/ Effect wheel/Framing module) reset	190	199					

			Total reset	200	209
			Reserved	210	229
			Reserved	240	255
43	48	63	Light Type		
			Type selected as per menu	0	39
			Moving Head 6-54°	40	59
			Zoom profile light 35-54°	60	79
			Zoom profile light 15-35°	80	99
			Zoom profile light 6-15°	100	119
			Fixed focus profile light 54°	120	139
			Fixed focus profile light 36°	140	159
			Fixed focus profile light 26°	160	179
			Fixed focus profile light 19°	180	199
			Fixed focus profile light 10°	200	219
			Fixed focus profile light 6°	220	255
44	49	64	LED brightness calibration		
			No	0	49
			LED brightness 50%-100%, linear calibration	50	100
			LED brightness 100%	101	255
45	50	65	LED brightness calibration confirmation		
			Ready to store calibrated value	0	200
			Store calibrated value in the fixture(stay in the DMX range for more than 5s)	201	209
			No	210	255
46	51	66	Reserved	0	255
47	52	67	Reserved	0	255

Remark:

1. Fan error can shut off light source.
2. "Speed Mode" means Pan and Tilt will move from Point A to Point B at their respective maximum speeds."Time Mode" means both Pan and Tilt will arrive at designated point at the same time. It's advised Time Mode be used if the projector runs circles or in oblique lines.
3. LED brightness standard with adjusting range between 50% and 100%. After completion, the desired parameters will be stored into the fixtures without repeated operations.

Procedures:

Step1: DMX value range for Channel LED brightness calibration is between 50 and 100 with according brightness range between 50% and 100%.











Step2:DMX value range for Channel LED brightness calibration confirmation is between 0 and 200. If the fader is moved between 201 and 209 and stays there for more than 5s, the desired brightness value will be stored into fixtures.

Step 3:Move the faders for DMX channels LED brightness calibration and LED brightness calibration confirmation respectively to zero.



If 100% brightness needed, move the fader for channel LED brightness calibration between 100 and 255 for Step 1 and repeat Step 2 and 3.

Under the menu, confirm Defaults/Restore default, LED brightness will go back to 100%.

8. SIGNS OF THE TOUCH SCREEN

	Lamp Control		Option Settings
	Chinese/English		Information
	Error Messages		Service
	Address		Operation Mode
	Reset		User Memories
	Config Settings		

9.ERROR MESSAGES

The system can detect some errors during the reset, if  displayed, touch  to view the error.
The error messages are as follows:

Name	Type	Correction
Pan	Timeout/magnet Sensor/Encoder	Check if wiring, positioning parts and motors are normal
Tilt	Timeout/magnet Sensor/Encoder	Check if wiring, positioning parts and motors are normal
Cyan	Timeout	Check if wiring, positioning parts and motors are normal
Yellow	Timeout	Check if wiring, positioning parts and motors are normal
Magenta	Timeout	Check if wiring, positioning parts and motors are normal
Color temperature	Timeout	Check if wiring, positioning parts and motors are normal
Color Wheel1	Timeout	Check if wiring, positioning parts and motors are normal
Color Wheel2	Timeout	Check if wiring, positioning parts and motors are normal
Fixed gobo wheel	Timeout	Check if wiring, positioning parts and motors are normal
Rot. Gobo Wheel	Timeout	Check if wiring, positioning parts and motors are normal
Rot. Gobo Rotation	Timeout	Check if wiring, positioning parts and motors are normal
Dimmer	Timeout	Check if wiring, positioning parts and motors are normal
Prism 1	Timeout	Check if wiring, positioning parts and motors are normal
Prism 1 Rotation	Timeout	Check if wiring, positioning parts and motors are normal
Prism 2	Timeout	Check if wiring, positioning parts and motors are normal
Prism 2 Rotation	Timeout	Check if wiring, positioning parts and motors are normal
Focus	Timeout	Check if wiring, positioning parts and motors are normal
Zoom	Timeout	Check if wiring, positioning parts and motors are normal
Effect Wheel	Timeout	Check if wiring, positioning parts and motors are normal
Effect Wheel Rotation	Timeout	Check if wiring, positioning parts and motors are normal
Pan Board	Error	Check signal wire

Tilt Board	Error	Check signal wire
Driver Board 1	Error	Check signal wire
Driver Board2	Error	Check signal wire
Driver Board 3	Error	Check signal wire
Driver Board 4	Error	Check signal wire
Framing board	Error	Check signal wire
Fan board	Error	Check signal wire
LampOff[Fan Error]	Error	Check if all fans are normal
Time IC	Error	Contact the manufacturer

10. TECHNICAL DATA

ELECTRICAL PARAMETERS

Input voltage: 100V-240V AC, 50/60Hz

Input power: 2100W@220V

Power factor: PF>0.95

Current at maximum: 9.5A @ 220V

OPTICAL SYSTEM

Light sources : 1800W white LED module

Colour Temperature : 8000K

CRI : Ra>95、R9>95

High out version : Ra≥70

Manufacturers Rated Lamp Life : ≥20000hrs

COLORS

CMY linear coloring mixing system with macros

2 Color Wheels

Color Wheels 1: Red, Green, Blue, Orange ,Pink, Light cyan,+ open

Color Wheels 2: Dark Red, Amber, Tea red, Apple green, Dark magenta,UV+ open

Full color/half color/linear color

Bi-directional rainbow effect with variable speeds

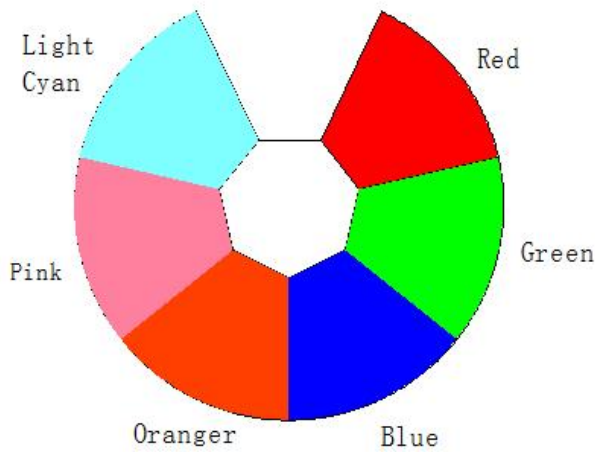

Color Wheels I

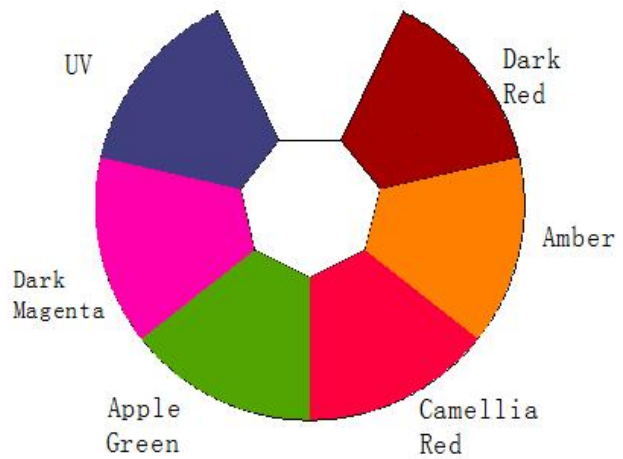

Color Wheels II

CTO

Linear CTO system(0-100%, 1800K-6500K)

FRAMING

Framing module:4 framing blades to make graphics with different sizes and shapes,

Each blade to make full curtain effect .Continual and bi-directional 360°rotation for the whole module

GOBOS

1 rotating gobo wheel: 6 exchangeable+ open

Bi-directional rotation, indexing, shake with varied speeds and bi-directional scrolling with varied speeds

Rotating gob wheel:

1#:	2#:	3#:	4#:	5#:	6#:

Gobo external size: 32mm

Image size: 25mm

1 fixed gobo wheel

7 exchangeable gobos+ open

Shake effect with varied speeds and bi-directional rotation with varied speeds

Fixed gob wheel

1#:	2#:	3#:	4#:	5#:	6#:	7#:

Gobo external size: 32mm

Image size: 25mm

EFFECT WHEEL

1 animation effect wheel, bi-directional rotation with varied speeds

IRIS

Linear iris 5-100% with macros

PRISM

1 pc of 4-facet circular prism+1 pc of linear prism, bi-directional rotation with varied speeds with indexing function

FROST

2 frost filters: 1 heavy frost filter + 1 light frost filter (0-100% linear)

BEAM ANGLE

Linear zoom 6°-54° with 16 bit precision

FOCUS

Linear focus with auto-focus function

DIMMER

Linear electronic dimmer 0-100% with 16 bit control

3 dimmer speeds

5 dimmer gamma curves

Dimmer frequency(1.2K-25K)

STROBE

Electronic strobe, 0.3~25 Hz, optional synchronized/ non-synchronized strobes

HEAD MOVEMENT

Pan 540°, Tilt 270° with auto position correction and 16 bit control

ADVANCED MACROS

Color temperature macros: optional 2700K,3000K,3500K,4000K,4500K,5000K,5700K

Standard color macros: 89 color options

FIXTURE TYPES

Including moving head light, fixed-focus profile light, zoom profile light

Moving head light with beam angle range(6-54°)

Fixed focus profile light with beam angle options including 6°,10°,19°,26°,36°,54°

Zoom profile light with beam angle ranges including 6-15°,15-35°,35-54°

(Note: Auto quiet theater mode for fixed focus profile light and zoom profile light)

FAN MODE

Standard mode and theater modes. Theater mode is quiet mode

BRIGHTNESS CALIBRATION FUNCTION

With brightness calibration function to calibrate initial brightness for a single fixture or multiple ones and store brightness values into the fixtures

CRI MODE

Running at high CRI mode via DMX channel to ensure high CRI optical effect.

CONTROL

International standard DMX512 signal and RDM function

47channels in short mode, 52channels in standard mode,67channel in extended mode

Art Net protocol , sCAN protocol(optional), DMX512 wireless control

CONTROL INTERFACE

DMX512 ports (5-pin)

Ethernet port RJ45

OTHER FUNCTIONS

Pan and Tilt speeds adjustable

Pan and Tilt swappable and invertible

High precision magnet sensor for positioning

3.2-inch touch color screen, Chinese and English menus, Screen automatic lock –up while standby

Error diagnostic system with sensors

Smart fan cooling system

Display of fixture hours and software versions

Modular construction for easy maintenance

Isolated input signals

Firmware update via DMX cable port

IP RATING

IP20

OPERATION TEMPERATURE

45°C at Maximum

WEIGHT

Net weight 47.8Kg

SIZES

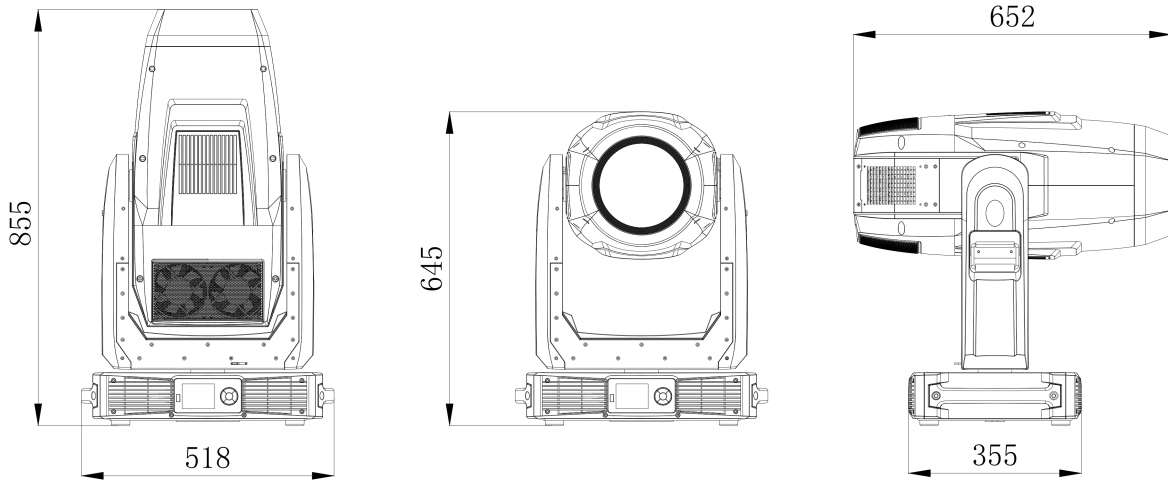

INSTALLATION DIAGRAM (BOTTOM VIEW)

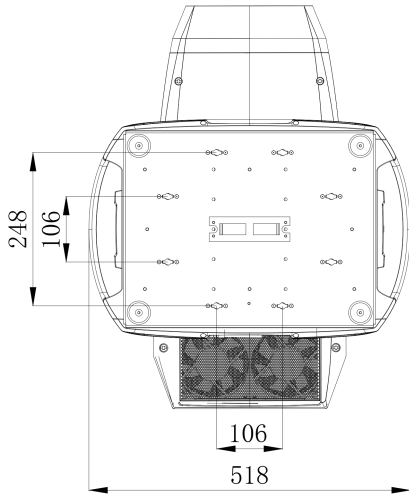
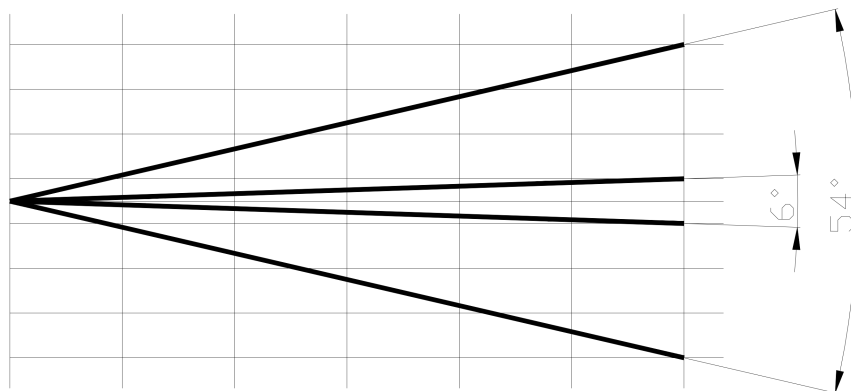

PHOTO METRICS

54° (lux)	4485	1121	498	280	179	125
6° (lux)	156520	39130	17391	9782	6261	4348



DISTANCE (m)	5m	10m	15m	20m	25m	30m
6° DIAMETER (m)	∅ 0.56	∅ 1.11	∅ 1.67	∅ 2.22	∅ 2.78	∅ 3.33
54° DIAMETER (m)	∅ 4.96	∅ 9.96	∅ 14.94	∅ 19.93	∅ 24.91	∅ 29.89

11. CIRCUIT DIAGRAM

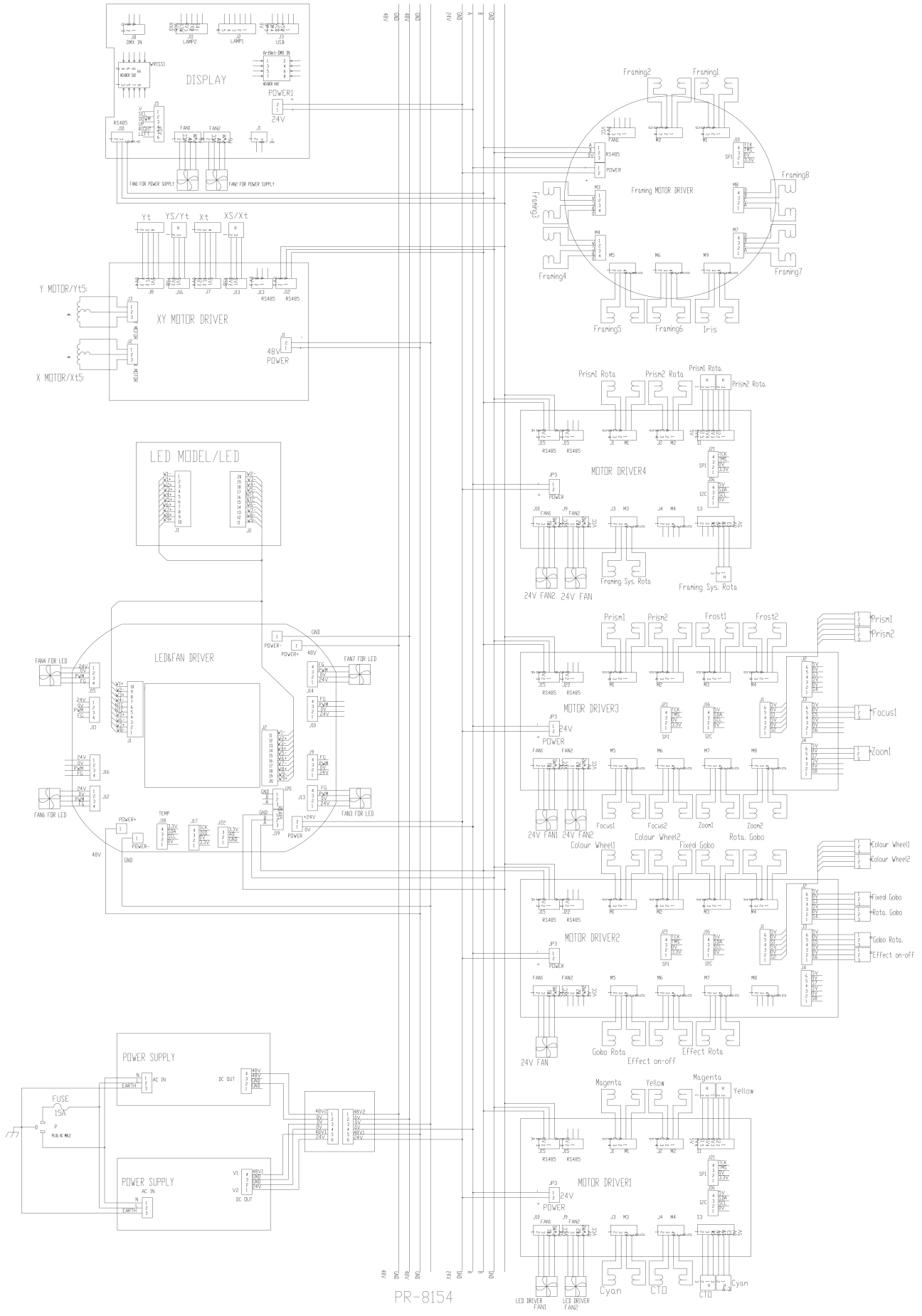

12. COMPONENT ORDER CODES

NAME	CODE NUMBER	QTY	REMARK
SWITCHING POWER SUPPLY	192010228A	1	
SWITCHING POWER SUPPLY	192010215B	1	
LED LIGHT SOURCE(HIGH CRI)	150020356	1	
PAN MOTOR	030040262	1	
TILT MOTOR	030040262	1	
PRISM IN/OUT MOTOR	030040221A	2	
PRISM ROTATING MOTOR	030040289	2	
FROST IN/OUT MOTOR	030040073D	2	
EFFECT WHEEL IN/OUT MOTOR	030040220A	1	
EFFECT WHEEL ROTATING MOTOR	030040220A	1	
GOBO WHEEL MOTOR	030040220A	1	
GOBO ROTATION MOTOR	030040125A	2	
COLOR WHEEL MOTOR	030040220A	2	
CMY MOTOR	030040210A	2	
	030040211A	2	
FOCUS MOTOR	030040291	2	
ZOOM MOTOR	030040261A	2	
FRAMING MODULE ROTATING MOTOR	030040303	1	
FRAMING BLADE MOTOR	030040283	8	
IRIS MOTOR	030040283	1	
BASE FAN	030060121A	2	
LED FAN	030060142	4	
DRIVER FAN	030060122	2	
GOBO FAN	030060115	1	
FRAMING MODULE FAN	030060120	2	
PRISM FAN	030060117	1	

13.LIGHTING FAN INSTALLATION POSITION

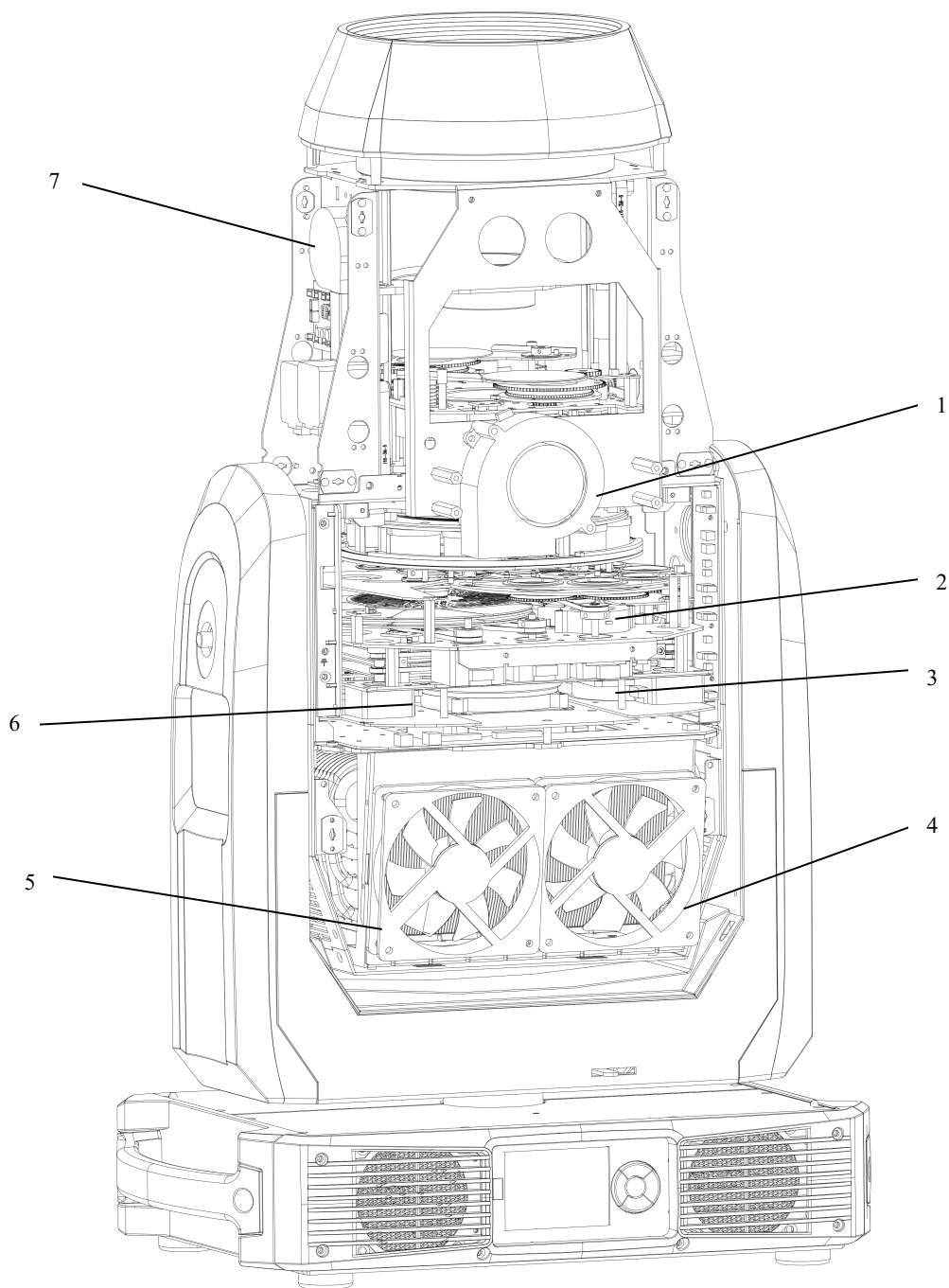

No.	Code No.	Name	Remark	Fan Position
1	030060120	Framing Fan1	PF97332B2-L03C-S99 24V 0.38A 4000	3-channel Motor driver PCB 4: FAN1
2	030060115	Gobo Fan	PF97332B2-L03C-S99 24V 0.38A 6000	7-channel Motor driver PCB 2: FAN1
3	030060122	LED.D Fan 2	EF80152B1-E04C-S99 24V 0.098A	4-channel Motor driver PCB 1:FAN2
4	030060142	LED Fan 1	MGT12024ZB-W25 24V 0.51A IP21	LED driver PCB: FAN 3
5	030060142	LED Fan 3	MGT12024ZB-W25 24V 0.51A IP21	LED driver PCB: FAN 6
6	030060122	LED.D Fan 1	EF80152B1-E04C-S99 24V 0.098A	4-channel Motor driver PCB1: FAN1
7	030060117	Prism Fan	06023GA-24N-AU-05 24V 0.17A	3-channel Motor driver PCB: FAN2

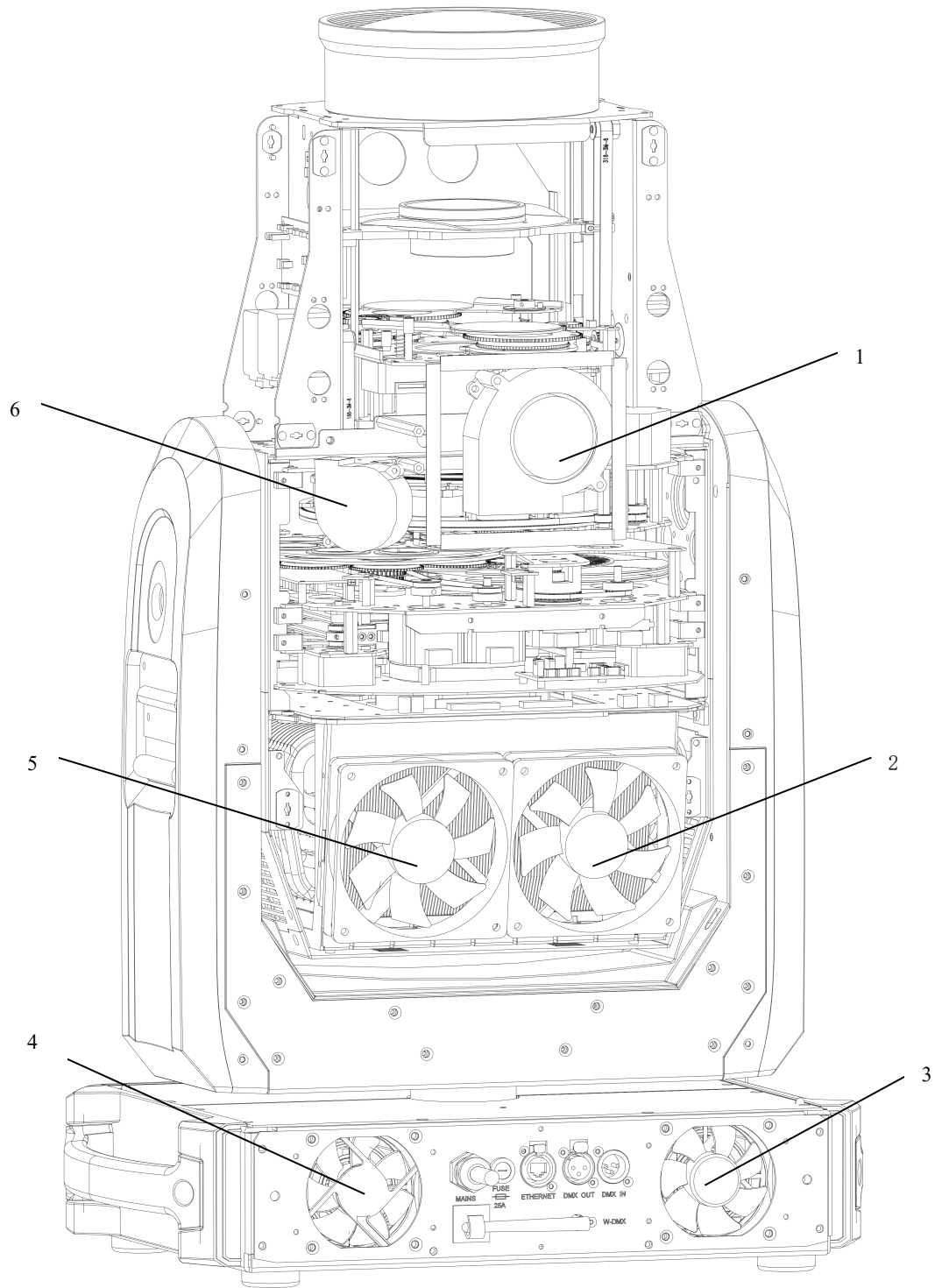

No.	Code No.	Name	Remark	Fan Position
1	030060120	Framing Fan2	PF97332B2-L03C-S99 24V 0.38A 4000	8-channel Motor driver PCB 3: FAN1
2	030060142	LED Fan 2	MGT12024ZB-W25 24V 0.51A IP21	LED driver PCB: FAN 4
3	030060121A	Base Fan 2	MGT8024UB-W25 24V 0.45A	Display driver PCB: FAN2
4	030060121A	Base Fan 1	MGT8024UB-W25 24V 0.45A	Display driver PCB: FAN1
5	030060142	LED Fan 4	MGT12024ZB-W25 24V 0.51A IP21	LED driver PCB: FAN 7
6	030060117	Lens Fan	06023GA-24N-AU-05 24V 0.17A	8-channel Motor driver PCB 3: FAN2

PR LIGHTING LTD.

1582 Xingye Avenue, Nancun Panyu
Guangzhou, 511442 China
TEL: +86-20-3995 2888
FAX: +86-20-3995 2330

PR lighting will try its best to offer accurate and overall information about a product's technical data. Any changes won't be notified if necessary.
Patented Products. Counterfeiting Will be Prosecuted!

P/N: 320021789
Version:20260528