

AQUA Laser 260 BWS

PR-8327

The user manual contains important information about the safe installation and use of a projector. Please read and follow these instructions carefully and keep the manual in a safe place for future reference.

PR LIGHTING LTD.
<http://www.pr-lighting.com>

INDEX

1. SAFETY AND WARNINGS.....	3
2. INSTRUCTIONS.....	4
3. APPEARANCE	5
4. INSTALLATION.....	5
5. SETUP AND CONFIGURATION.....	9
6. OPERATION MENU.....	10
7. DMX PROTOCOL.....	14
8. ERROR MESSAGE.....	18
9. SIGNS ON THE TOUCH SCREEN	19
10. TECHNICAL DATA.....	19
11. CIRCUIT DIAGRAM.....	23
12. COMPONENT ORDER CODES.....	25

ACCESSORIES

The following items are supplied with the projector and please check:

Name	Quantity	Unit	Remark
G clamps	2	Pcs	
XLR connectors	1	Set	Male and female
Safety cord	1	Pc	
User manual	0	Pc	QR Code
Ω clamps	2	Pcs	Optional

Please note that as part of our ongoing commitment to continuous product development, specifications are subject to change without notice. Whilst every care is taken in the preparation of the manual we reserve the right to change specifications in the course of product improvement. The publishers cannot be held responsible for the accuracy of the information herein, or any consequence arising from them.

Every unit is tested completely and packed properly by the manufacturer. Please make sure the packing and / or the unit are in good condition before installation and use. Should there be any damage caused by transportation, consult your dealer and do not use the unit. Any damage caused by improper use will not be assumed by the manufacturer and / or dealer.

Note: For the products made by Guangzhou PR lighting Ltd, the warranty for the whole product is one year starting from the delivery date but the light source is not within the warranty.







1. SAFETY AND WARNINGS



NOTE

Before a projector's installation, power-on, operation and maintenance, please carefully read the safety information hereinafter!

The following safety signs are used in the user manual.

						
Warning	User Manual	Electrical shock	Goggles	Protective Gloves	Flames	High Temperature



- When unpacking, check if there is transportation damage before using a projector. Should there be any damage caused by transportation, consult your dealer and do not use it.
- The manufacturer is not responsible for any loss caused by the user not following the manual or changing a projector as he/she likes.
- Please be noted that the damage caused by changing a projector at will is not warranted.
- Do not hesitate to contact the dealer or the manufacturer if any questions or advice.
- If a lamp is damaged or deforms because of heat, it should be replaced. (It applies only to traditional lamps)



- The projector is for indoor and outdoor use, IP66.
- It can be used in humid and dusty areas. And it can contact water and other non-corrosive liquids.
- The projector should be kept away from high temperature, fire, electrical surge, vibration and strong light while being operated
- The projector is only intended for installation, operation and maintenance by qualified personnel. And the operation must strictly follow the procedures in the manual
- No repairable parts in the projector and do not open covers for maintenance by yourself.



- Don't look straightly into the light sources especially for epileptics, otherwise eyes will be burned.
- Do not connect a projector to any type of dimmer pack.
- If the lamp, lens and screen protective cover of the a projector have obvious damage, i.e., to the extent that it hurts the performance like cracking or deformation. Please stop using it and replace them with the original parts, otherwise its performance will be compromised.
- For the installation location of a projector, it shouldn't be seen in the distance of less than 4 meters for a long time.



- Before operation, please confirm that all covers (housing) are on and screws tightened. It's forbidden to use a projector while covers (housing) are off.
- Keep the lamp clean and do not touch it with bare hands.
- While operating it, wear protective items like eye goggles , gloves and etc..



- Any electrical connection must be carried out by a qualified person .
- Before installation, please confirm the voltage supplied matches what is required for a projector.
- Each projector must be properly earthed and installed as per related electrical standards.
- Do not use power cord with its insulator damaged and connect the power cord with other cables.
- If a projector is not used or under cleaning,, please hold the plug and unplug it. Do not unplug it forcefully or by pulling the power cable.

- All power cords must conform to related safety and regulations.
- If a projector is not water and dust proof, while being operated it should not be under rains or in humidity to avoid short circuit.
- Do not switch on and off a projector constantly in very short intervals, otherwise the light source's and other electrical parts' life will be shortened .



- There are safety cord holes at the bottom of the base of a projector. In view of safety, please run the safety cord supplied through the safety cord holes for safety support.
- Before any installation, maintenance and cleaning work, please ensure a projector is disconnected from power mains.



- While running normally under normal ambient temperature, the temperature of the external surface of the metal housing of a projector including that of the heat sink may reach 75°C at maximum.
- While the lamp is stricken for the first time, there will be smoke and strange smell. It's normal and does not mean a projector has some defects.



- While it running, don't touch the metal housing to avoid being burned!
- Do not mount a projector directly on inflammable surface.
- Do not project the beam straightly on combustible items and the minimum distance between a projector and illuminated items is 18m.
- A projector should be installed with good ventilation and the minimum distance between a projector and a wall is 50cm. At the same time, please ensure the fans and air inlets and outlets are workable.
- Do not let the front lens under sunlight or other strong light sources at any angle, otherwise the danger of fire can be caused by the focused beam by the lens inside a projector.



- The product meets The General Technical Requirements and Standards for Recycle and Use Of Expired Appliance and Electronic Products.
- When the product meets disposal standards and needs to be disposed, a client needs to dispose and recycle it.

2. INSTRUCTIONS

●CLEANING AND MAINTENANCE

Under normal running, the protective units of a projector should be inspected regularly like power fuse. If it is burned, please install a new one and ensure it is the same rating as the burned one. For a projector with an over-temperature protective unit, please inspect cooling units regularly like cooling fans, heat sink and other cooling parts. Please check if the fans run normally or fans and air inlets are blocked by dust. To keep air inlets /outlets clean, cooling fans should be cleaned every 15days.

For projectors with lens, reflectors and coated filters, the accumulation of oil, smoke and dust on them will compromise the light output. Cleaning a projector is very necessary to ensure a reliable use. Internal and external lens, flat glass, reflector and coated filters need to be cleaned periodically to optimize light output.

Cleaning frequency is to be decided by operations and its environment. Use soft cloth and normal detergent for glass for cleaning work. It's advised external optical system be cleaned every 20days and internal optical systems every 30/60days. For a projector with high IP rating, if no damage inside, it is advised to clean the surfaces of its housing in principle. Keep lens clean and do not touch optical parts with bare hands.

SPECIAL NOTE:

It's normal phenomena that there will be mild water mist on the lens while the waterproof product is in use.



- Before any maintenance and cleaning, please ensure a project is off the power.
- Only a qualified person is allowed to do maintenance.



- To avoid sunlight or other light penetrating into the head via the front lens, resulting in high temperature internally causing damages to a projector. Before power-off, please use Tilt channel to move the head and make the head facing downward.
- Do not use alcohol or other organic solvent to clean the housing to avoid damage.
- Do not use any solvent with chemical elements to clean coated filters.

● **LUBRICATION**

To ensure smooth movement of gobos and zoom and focus lens, it's advised rotators' bearings and 2 sliding bars for zoom and focus lens be lubricated every 2 months. High quality and high temperature lubricant/grease is advised..

● **TROUBLESHOOTING**

PROBLEM	ACTION
A projector doesn't switch on	<ul style="list-style-type: none"> ➤ Check the fuse on the power socket. ➤ Check the lamp.
The lamp is on but a projector doesn't respond to the controller	<ul style="list-style-type: none"> ➤ Make sure that the fixture's start address is right ➤ Replace or repair the XLR signal cable.
A projector functions intermittently	<ul style="list-style-type: none"> ➤ Make sure the fan is working well or fans and their shields are not blocked
Beam appears dim, Low in brightness	<ul style="list-style-type: none"> ➤ Make sure the lamp is within its lifespan ➤ Remove dust or grease from the lenses.
The project image appears to have a halo	<ul style="list-style-type: none"> ➤ Carefully clean the lamp, optical lenses and other components.
Heavily Defective Beam	<ul style="list-style-type: none"> ➤ Check if lens are in good condition(not cracked) ➤ Clean dust or grease on the lens.

3. APPEARANCE

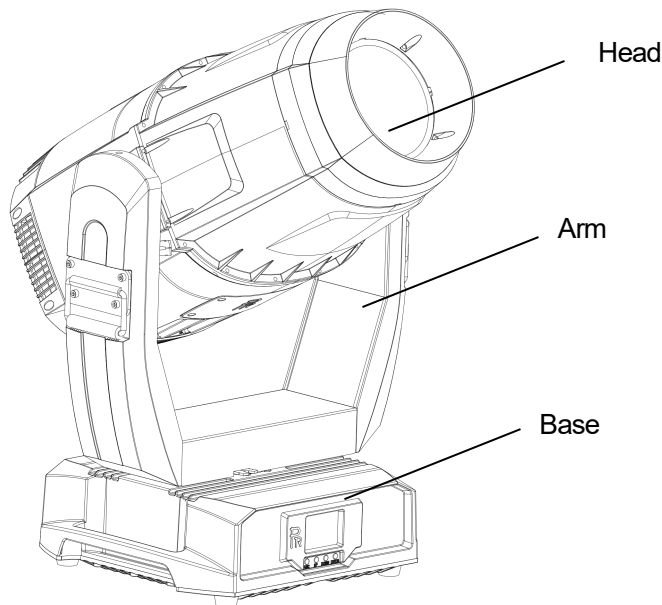

4. INSTALLATION

● **RIGGING**

Before moving a projector, Please lock Pan and Tilt. Before its operation, please unlock them. It's forbidden to run a projector with power while it is locked.

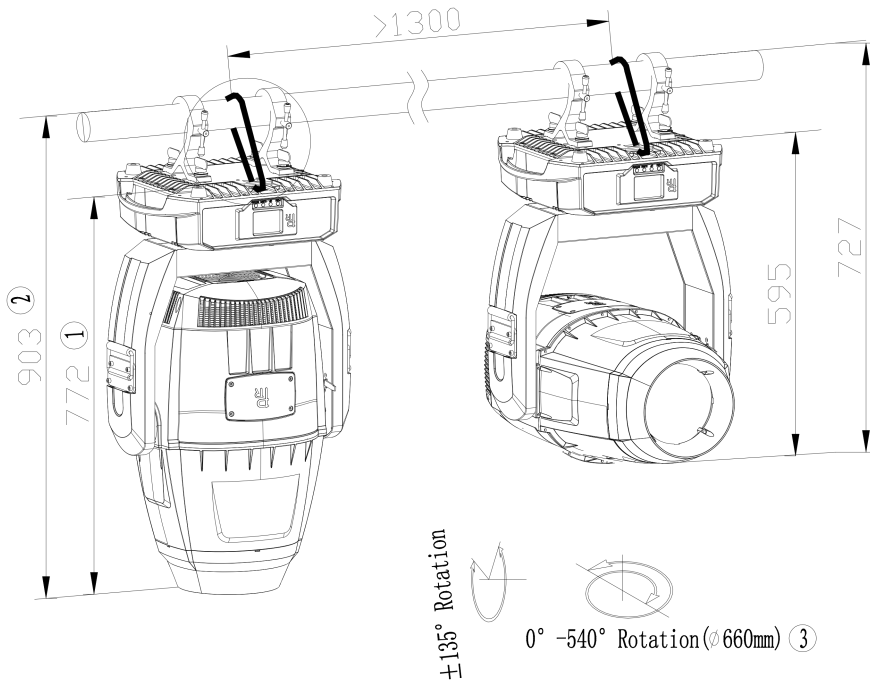

Note:

1. the distance between the foot of the base and the front lens cover (the head facing downward)
2. the distance between mounting truss and the front lens cover (the head facing downward)
3. The maximum diameter of the rotating head (minimum spacing between fixtures)

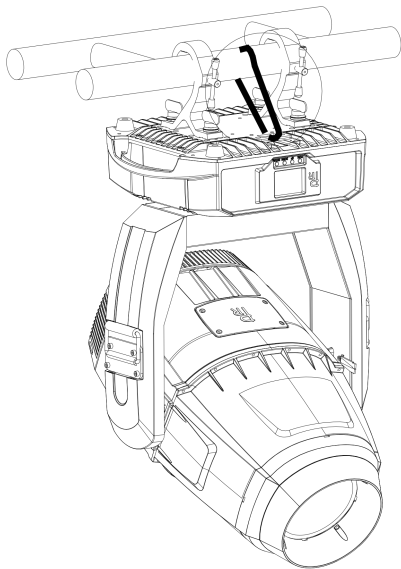

Warning!

For safety, please run the safety cord through its hole.

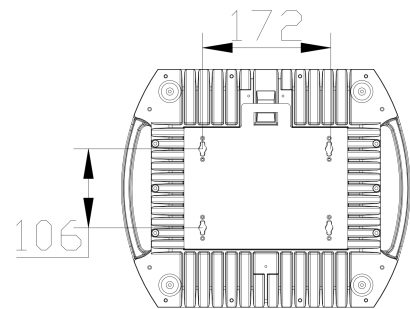
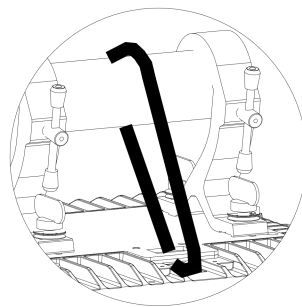

Take 2 clamps and the safety cord out from the package and mount 2 clamps on the underside of fixture with 2 retainers attached to each clamp. Hang the fixture on the structure and fasten the screws attached to each clamp. (See the **WARNING** on the underside of the base as shown above) **To pass the SAFETY CORD through the HOLES for safety!** Always ensure that the projector is firmly anchored to avoid vibration and slipping whilst functioning. Always ensure that the structure that you are going to mount the projector to is secure and strong enough to support the weight of a XR 1000 Framing.



WARNING:

- The projector **MUST** be lifted or carried by the **HANDLES** instead of clamps.
- For safety the safety cord should afford 10 times the Projector's weight.

• **POWER CONNECTION**

Connect the power cord as follows:

- L (live) =brown
- E (earth) =yellow/green
- N (neutral) =blue

Before power connection, please ensure the power supplied must match what the nameplate says. It is recommended that each projector be connected with power separately so that they may be individually switched on and off.



- The earth wire(yellow/green) must be connected to the ground. And electrical connection must be in accordance with the standards concerned.
- If any questions about the electrical installation, do not continue but consult a qualified electrician.

DMX CONTROL CONNECTION:

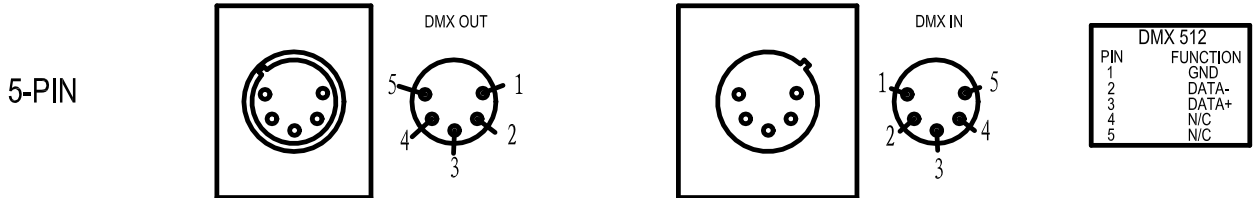

Connection between controller and projector and between one projector and another must be made with a twin-screened cable, with each wire having at least a 0.5mm in diameter. Connection to and from the projector is via cannon 5 pin (which are included with the projector) or 5 pin XLR plugs and sockets. The XLR's are connected as shown in the figure above.

Note: care should be taken to ensure that none of the pins touch the metallic body of the plug or each other. XLR plugs and sockets mustn't be connected in any way other than mentioned in the above figure. The Fixture accepts digital control signals in protocol DMX512 (1990).

Connect the controller's DMX output to the first fixture's DMX input, and connect the first fixture's DMX output to the second fixture's DMX input and connect the rest fixtures in the same way. Eventually connect the last fixture's DMX output to a DMX terminator as shown in the figure below.

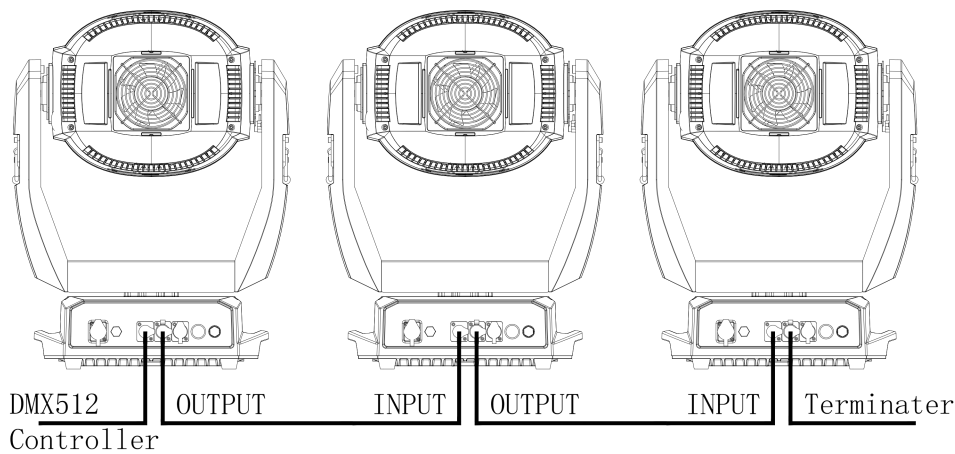

DMX TERMINATOR

In the Controller mode, at the last fixture in the chain, the DMX output has to be connected with a DMX terminator. This prevents electrical noise from disturbing and corrupting the DMX control signals.

The DMX terminator is simply an XLR connector with a 120Ω (ohm) resistor connected across pins 2 and 3, which is then plugged into the output socket on the last projector in the chain. The connections are illustrated below.

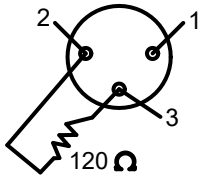

**DMX TERMINATOR
CONNECTION**

Connect a 120Ω(OHM) resistor
across pins 2 and 3 in an XLR plug
and insert into the DMX out socket
on the last unit in the chain.

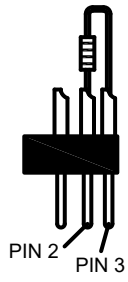

•ALIGNMENT/INSTALLATION/REPLACEMENT OF A LAMP

Please hold the head well before adjustment/installation/replacement of the light sources. As shown in figure1, remove fan cover of the head and heat sink.

Removal/Installation of the light source as shown in figure2

Adjust the light source as shown in figure3

Before the removal of the light source, unplug the light source wires. And plug light source wires after a new one is in.



- Don't touch the surface of the lens of the lamp with bare hands so as not to impair the beam output.
- Please read "Instructions " enclosed with the light source
- While adjusting the light, it is forbidden to carry out the functions not associated with lamp adjustment.

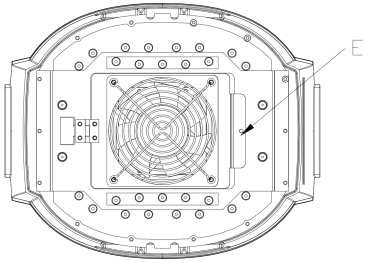
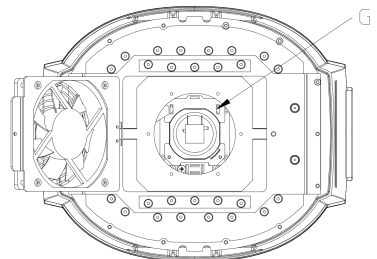
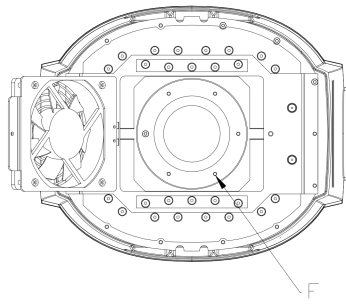
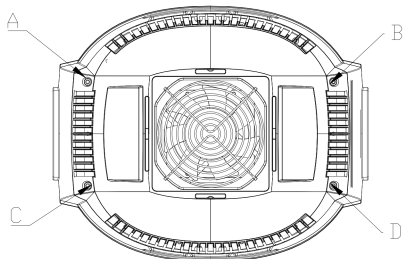

The steps for replacement/adjustment of the light source :

Figure1:Loosen A,B,C,D 4 screws of the bottom cover of the head before removing it. Then loosen the screw E of fan mounting plate and pull open the fan assembly, exposing the light source chamber cover.

Figure2: Loosen 6 screws F for the light source chamber cover , remove it and take care not to let seal fall off.

Figure3:Loosen 4 screws of the light source clipping plates and push the light source towards the clipping plate till it can be removed .Take out the light source and unplug its wires. Place a new light source, plug its wires, put back the light source chamber cover, tighten the screws and ensure the seal in the right place. At last restore all structures original positions.

1. After the projector is powered on, disable the following function in the menu: services-factory mode- light source fan sensor , then shut it from power
2. Loosen the 4 screws of the fan cover and remove it.
3. Loosen 4 screws of the fan plate, remove the fan and the clump weight, loosen 10 screws of the heat sink and remove it.
4. Push the upper clipping plate of the light source towards the spring, and at the same time pus the light source towards the opposite till it is off the plate and remove it obliquely,
5. The installation of the light source is the same as its removal
6. Check if the light source wires are plugged well, then turn on the light source for adjustment
7. After the adjustment of the light source, activate the following function in the menu: services-factory mode- light source fan

- sensor. Then shut it from the power
8. Check if the seals are good or not. If not, replace them with good ones. If no, install the heat sink, fan and fan cover in the opposite sequences as the removal.
 9. After installation, power it on. The projector will execute the total reset. After that, the projector can be used normally.

•GOBO REPLACEMENT

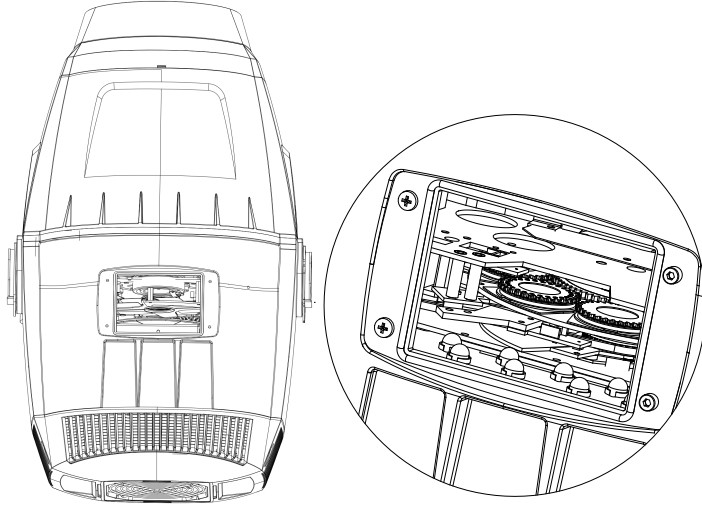

Replacement of the Gobos:

Open the chamber cover after loosening 4 screws. Select the rotator for replacement of gobo. Push the rotator at the opposite side of its gear till it is off the holder of the rotating gobo wheel. Remove the rotator gently. After replacement of the gobo, place the rotator into the wheel and ensure it is in the right position and not loose.

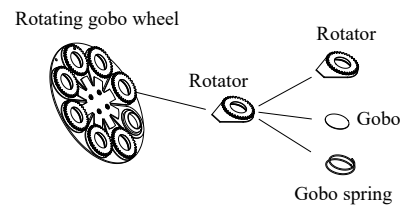

5. SETUP AND CONFIGURATION

•FRONT PANEL OPERATION

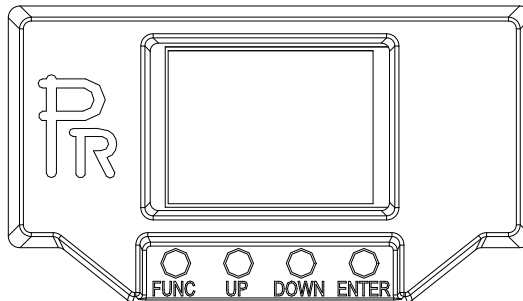

To browse through or change the projector's settings, press ENTER key for more than 3s (press ENTER key after power on) to unlock the screen, then press UP/DOWN key to enter the projector's function menus. Each main menu has its sub-menus. And each menu stands for special function. For the details, please see the following 6th point "Operation Menu".:

1. At the page to set the fixture's functions, press **UP** or **DOWN** key to select the functions desired.
2. While menu operations, the **FUNC** key to escape, and **ENTER** key is used to confirm. Press **ENTER** key to save the changes or enter into the sub menus. Press **UP** or **DOWN** key to change the numbers (minus or plus).

Press FUNC key to go to the uppler menu. If no key is pushed, the system will go back to initial status automatically.

•DMX START ADDRESS

Each projector must be given a DMX start address so that the correct projector responds to the correct control signals. This DMX start address is the channel number from which the projector starts to "listen" to the digital control information being sent out from the controller. The projector has 3 DMX modes. There are standard mode, short mode and extended mode. For example standard mode has 28 channels, so set the No. 1 projector's address 001, No. 2 projector's address 029, No. 3 projector's address 057, No. 4 projector's address 085, and so on.

Switch on the Projector . Press **ENTER** key more than 3 seconds to unlock panel, then press **UP** or **DOWN** key to enter into the fixture’s operation menus.

Select DMX Address icon and press ENTER key on the display and select DMX address at the 2nd level menu for the address setting. Press **UP** or **DOWN** key for the DMX address desired.

Press **ENTER** key to confirm.

Press the **FUNC** key to go back to the upper level menu.

•DMX WIRELESS CONTROL(Only for fixtures with wireless control)

The projector has wireless control function with wireless receiver module and antenna for remote control.

The setup of it is below:

1. Press **ENTER** for more than 3s to unlock the control panel, then press **UP** or **DOWN** key to enter into the operation menu and select “Config Settings”.
2. Select “Wireless Only” from the menu of “Signal Select”.

Only after the projector is linked with a transmitter, can it receive wireless signal sent by the transmitter. If unlinking it, Press “Enter” for the menu of Un-link Wireless under the upper level menu of Config Settings , then the fixture is unlinked with the wireless transmitter.

•STAND-ALONE MODE

Operate the projector without connecting with a controller, enable the master mode through the operation panel, the projector will run in Stand-Alone mode automatically.

DMX address can be set at any number within 512.

•MASTER/SLAVE MODE

Many projectors can run synchronously in the Master/Slave mode by linking them with each other. First, connect the first fixture’s DMX output to the second fixture’s DMX input using XLR-XLR control cable and then connect the second fixture’s DMX output to the third fixture’s DMX input, and so on until all projector are connected in this way. Eventually connect the last fixture’s DMX output to a DMX terminator. Set 1st projector as the master and others are Slaves.

Start Addresses of all Slaves are 001; Operation mode of the Master can be set any mode for a Master’ and Slaves’ operation mode can be set accordingly.

After Powered on, the group will run in Master/Slave Mode

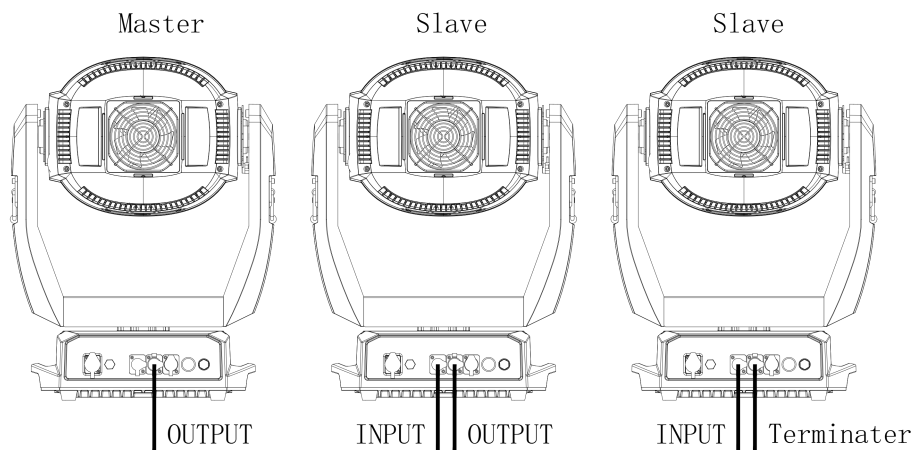

6. OPERATION MENU

1st LEVEL	2nd LEVEL	3rd LEVEL	4th LEVEL	5th LEVEL
Address	DMX Address	1-490(Short Mode) 1-485(Standard Mode)		

		1-482(Extend Mode)			
	IP Address	Default IP Address	2.X.X.X/10.X.X.X		
		Custom IP Address	X.X.X.X		
	SubNet Mask	X.X.X.X			
	ArtNet ArtNet Universe	0-255			
	sACN universe	1-63999			
Reset	Total Reset	Really Reset? Confirm or Cancel			
	Pan&Tilt Reset	Really Reset? Confirm or Cancel			
	Colour System Reset	Really Reset? Confirm or Cancel			
	Gobo Reset	Really Reset? Confirm or Cancel			
	Zo. Fo.Fr. Pr. Reset	Really Reset? Confirm or Cancel			
Config Settings	DMX Channel Mode	Short Mode 23CH			
		Standard Mode 28CH			
		Extended Mode 31CH			
		View Selected Mode	Ch.01 Strobe Ch.02 Dimmer ... Ch. XX control function		
	Signal Select	XLR Only			
		XLR First			
		Wireless Only			
		Wireless First			
		Wireless In/XLR Out			
		Artnet Only			
		Artnet In/XLR Out			
		sACN only			
	Loss of DMX	Normal time out			
		Hold Last Value			
	Display Config	Display Mode	Off After Delay		
			On Always		
		Display Invert	Invert OFF		
			Invert ON		
	Language Setting	English\Chinese			
	Temperature Unit	Celsius Degree			
		Fahrenheit Degree			
	Un-Link Wireless	Really Un-Link? Confirm or Cancel			
	Factory Defaults	Restore Defaults? Confirm or Cancel			
Option Settings	Pan/Tilt Settings	Pan DMX Invert	OFF/ ON		
		Tilt DMX Invert	OFF/ ON		
		Pan Tilt Swap	OFF/ ON		
		XY Feedback	OFF/ ON		
		Pan/Tilt mode	Speed/Time	Note: "Speed Mode" means Pan and Tilt will move from Point A to	

				Point B at their respective maximum speeds."Time Mode" means both Pan and Tilt will arrive at designated point at the same time. It's advised Time Mode be used if the projector runs circles or in oblique lines.
	Invert Settings	CYM Invert	OFF/ON	
	Dimmer Settings	Dimmer Speed	Fast/Medium/Slow Speed	
	Defaults			
Information	View DMX Values	Channel Value Strobe XXX Dimmer XXX CMY macro XXX Cyan XXX Yellow XXX Magenta XXX Color Wheel XXX FixedGoboWheelXXX Rota. Gobo wheel XXX Gobo Rota. XXX Prism 1 XXX Prism 1 Rotation XXX Prism 2 XXX Prism 2 Rotation XXX Frost XXX Focus XXX Zoom XXX Pan XXX Tilt XXX Control Function XXX		
	Lamp hours	XXX h		
	Total hours	XXXh		
	Temperature	Display Board=xxx°C Pan board=xxx°C Tilt board=xxx°C Motor driver board 1=xxx°C Motor driver board2=xxx°C Light source driver board=xxx°C Light source=xxx°C		
	Software Version	PCB Sys. bootloader Display Board xxx xxx Pan board xxx xxx Tilt board xxx xxx Motordriverboard1 xxx xxx Motordriverboard2 xxx xxx Lightsource driverboard x xx xx		
	Electronic SN	XXXXXX		
	RDM Device Label	XXXXXX ANSI E1.20 RDM		
	Fan Status	Fan Speed RSpeed Base fan xxx on/off Lens fan xxx on/off Lightsourcefan xxx on/off		
	Lamp Fan Error	Fan DMX channel Base fan xxx Lens fan xxx Lightsource fan xxx		
	Service	Manual Effect	Channel Value Strobe XXX	

	Control	Dimmer XXX CMY macro XXX Cyan XXX Yellow XXX Magenta XXX Color Wheel XXX FixedGoboWheelXXX Rota. Gobo wheel XXX Gobo Rota. XXX Prism 1 XXX Prism 1 Rotation XXX Prism 2 XXX Prism 2 Rotation XXX Frost XXX Focus XXX Zoom XXX Pan XXX Tilt XXX		
	Factory Mode	XXX		
Operation Mode	DMX Mode	Change Operation Mode? Confirm or Cancel		
	Master Mode	Preset Memory	Change Operation Mode? Confirm or Cancel	
		User Memory 1	Change Operation Mode? Confirm or Cancel	
		User Memory 2	Change Operation Mode? Confirm or Cancel	
	Stand-Alone Mode	Preset Memory	Change Operation Mode? Confirm or Cancel	
		User Memory 1	Change Operation Mode? Confirm or Cancel	
		User Memory 2	Change Operation Mode? Confirm or Cancel	
Static Scene	Change Operation Mode? Confirm or Cancel			
User Memories	Edit User Memory	Edit User Memory 1 / Edit User Memory 2	(1~200 Scenes) Scene XX (1~200 Scenes)	Channel Value Strobe XXX Dimmer XXX CMY macro XXX Cyan XXX Yellow XXX Magenta XXX Color Wheel XXX FixedGoboWheelXXX Rota. Gobo wheel XXX Gobo Rota. XXX Prism 1 XXX Prism 1 Rotation XXX Prism 2 XXX Prism 2 Rotation XXX Frost XXX Focus XXX Zoom XXX Pan XXX Tilt XXX Hold time XXX Delay Time XXX Delay time unit ms/s/m Link to next scene XXX
		Edit Static Scene	Paste? Confirm or Cancel	Channel Value Strobe XXX Dimmer XXX CMY macro XXX Cyan XXX Yellow XXX Magenta XXX Color Wheel XXX FixedGoboWheelXXX Rota. Gobo wheel XXX Gobo Rota. XXX Prism 1 XXX

				Prism 1 Rotation XXX Prism 2 XXX Prism 2 Rotation XXX Frost XXX Focus XXX Zoom XXX Pan XXX Tilt XXX
	Init User Memory	Reset User Memory 1	Reset User Memory? Confirm or Cancel	
		Reset User Memory 2	Reset User Memory? Confirm or Cancel	
		Reset Static Scene	Reset Static Scene? Confirm or Cancel	

7. DMX PROTOCOL

Short mode	Standard Mode	Extended Mode	FUNCTION	DMX	DESCRIPTION
1	1	1	Strobe	000	Close
				001-127	Pulse strobe speed from slow to fast
				128-255	Strobe speed from slow to fast
2	2	2	Dimmer	000-255	Linear dimming (0-100%)
	3	3	Dimmer Fine	000-255	Dimmer in 16 bit
3	4	4	CYM Macro	000-016	Open
				017-035	Yellow+Magenta=Red
				036-054	Yellow
				055-073	Yellow+Cyan=Green
				074-092	Cyan
				093-111	Cyan +Magenta= purple
				112-128	Magenta
129-255	CYM color mixing from slow to fast				
4	5	5	Cyan	000-255	Cyan (linear 0~100%)
		6	Cyan Fine	000-255	Cyan in 16 Bit
5	6	7	Yellow	000-255	Yellow (linear 0~100%)
		8	Yellow Fine	000-255	Yellow in 16 Bit
6	7	9	Magenta	000-255	Magenta (linear 0~100%)
		10	Magenta Fine	000-255	Magenta in 16 Bit
7	8	11	Color Wheel	000-063	Indexing(0-360degrees)
				064-067	Open
				068-070	Color1
				071-073	Color2
				074-076	Color3
				077-079	Color4
				080-082	Color5
				083-085	Color6
				086-088	Color7
				089-091	Color8
				092-094	Color9
095-097	Color10				
098-100	Color11				

				101-103	Color12
				104-106	Color13
				107-109	Color14
				110-112	Color15
				113-115	Color16
				116-118	Color17
				119-121	Color18
				122-124	Color19
				125-127	Open
				128-191	Rotation ,Clockwise from slow to fast
				192-255	Rotation, Anti-clockwise from fast to slow
	9	12	Color Wheel Fine	0000-255	Color Wheel in 16 Bit
8	10	13	Fixed Gobo Wheel	000-011	Open
				012-015	Gobo1
				016-019	Gobo2
				020-023	Gobo3
				024-027	Gobo4
				028-031	Gobo5
				032-035	Gobo6
				036-039	Gobo7
				040-043	Gobo8
				044-047	Gobo9
				048-051	Gobo10
				052-055	Gobo11
				056-059	Gobo12
				060-063	Gobo13
				064-067	Gobo14
				068-071	Gobo15
				072-075	Gobo16
				076-079	Gobo17
				080-083	Gobo18
				084-087	Gobo19
				088-091	Gobo20
				092-095	Gobo21
				096-099	Gobo22
				100-103	Gobo23
				104-107	Gobo24
				108-111	Gobo25
				112-115	Gobo26
				116-119	Gobo27
				120-123	Gobo28
				124-127	Gobo29
				128-149	Clockwise rotation from slow to fast
				150-171	Anti Clockwise rotation from slow to fast

				172-174	Shake effect 1 from slow to fast
				175-177	Shake effect 2 from slow to fast
				178-180	Shake effect 3 from slow to fast
				181-183	Shake effect 4 from slow to fast
				184-186	Shake effect 5 from slow to fast
				187-189	Shake effect 6 from slow to fast
				190-192	Shake effect 7 from slow to fast
				193-195	Shake effect 8 from slow to fast
				196-198	Shake effect 9 from slow to fast
				199-201	Shake effect 10 from slow to fast
				202-204	Shake effect 11 from slow to fast
				205-207	Shake effect 12 from slow to fast
				208-210	Shake effect 3 from slow to fast
				211-213	Shake effect 14 from slow to fast
				214-216	Shake effect 15 from slow to fast
				217-219	Shake effect 16 from slow to fast
				220-222	Shake effect 17 from slow to fast
				223-225	Shake effect 18 from slow to fast
				226-228	Shake effect 19 from slow to fast
				229-231	Shake effect 20 from slow to fast
				232-234	Shake effect 21 from slow to fast
				235-237	Shake effect 22 from slow to fast
				238-240	Shake effect 23 from slow to fast
				241-243	Shake effect 24 from slow to fast
				244-246	Shake effect 25 from slow to fast
				247-249	Shake effect 26 from slow to fast
				250-252	Shake effect 27 from slow to fast
				253-255	Shake effect 28 from slow to fast
9	11	14	Rotating Gobo Wheel	000-007	Open
				008-017	Gobo 1
				018-027	Gobo 2
				028-037	Gobo 3
				038-047	Gobo 4
				048-057	Gobo 5
				058-067	Gobo 6
				068-077	Gobo 7
				078-087	Gobo 8
				088-097	Gobo 9
				098-107	Gobo 10
				108-117	Gobo 11
				118-127	Gobo 12
				128-143	Rotation (clockwise From slow to Fast)
				144-159	Reverse Rotation (anti-clockwise From slow to Fast)



				160-167	Shake of Gobo 1 from slow to fast
				168-175	Shake of Gobo 2 from slow to fast
				176-183	Shake of Gobo 3 from slow to fast
				184-191	Shake of Gobo 4 from slow to fast
				192-199	Shake of Gobo 5 from slow to fast
				200-207	Shake of Gobo 6 from slow to fast
				208-215	Shake of Gobo 7 from slow to fast
				216-223	Shake of Gobo 8 from slow to fast
				224-231	Shake of Gobo 9 form slow to fast
				232-239	Shake of Gobo 10 from slow to fast
				240-247	Shake of Gobo 11 from slow to fast
				248-255	Shake of Gobo 12 from slow to fast
10	12	15	Gobo Rotation	000-128	Gobo Indexing(0~540degrees)
				129-188	Rotation (Clockwise From slow to Fast)
				189-195	Stop
				196-255	Rotation (Anti-Clockwise From slow to Fast)
	13	16	Gobo Rotation Fine	000-255	Gobo Rotation in 16 Bit
11	14	17	Prism Wheel 1	000-016	Open
				017-127	Prism1
				128-255	Prism2
12	15	18	Prism Wheel 1 Rotation	000-127	Prism Indexing
				128	Stop
				129-191	Rotation(Clockwise from slow to fast)
				192	Stop
				193-255	Rotation(Anti- Clockwise from slow to fast)
13	16	19	Prism Wheel 2	000-016	White
				017-127	Prism3
				128-255	Prism4 (gradient prism)
14	17	20	Prism Wheel 2 Rotation	000-127	Prism2 Indexing
				128	Stop
				129-191	Rotation(Clockwise from slow to fast)
				192	Stop
				193-255	Rotation(Anti- Clockwise from slow to fast)
15	18	21	Frost	000-009	Open
				010-255	Frost in
16	19	22	Focus	000-255	Linear focus
	20	23	Focus Fine	000-255	Focus in 16 bit precision
	22	25	Zoom	000-255	Linear zoom
18	23	26	Zoom Fine	000-255	zoom in 16 bit precision
18	23	26	Pan	000-255	Pan(0°~540°)
19	24	27	Pan Fine	000-255	Pan in 16 bit
20	25	28	Tilt	000-255	Tilt(0°~270°)

21	26	29	Tilt Fine	000-255	Tilt in 16 bit
22	27	30	Pan & Tilt Speeds	000-255	Pan & Tilt Speed from Fast to Slow
23	28	31	Control	000-019	Reserved
				Stay within DMX range for more than 5S to activate the following functions.	
				020-024	Graphic Display On
				025-029	Graphic Display Off
				030-052	Reserved
				053-054	Fast Dimmer
				055-056	Medium Dimmer
				057-058	Slow Dimmer
				059-089	Reserved
				090-094	Pan & Tilt Speed Mode
				095-099	Pan & Tilt Time Mode
				100-139	Reserved
				140-149	Pan & Tilt Reset
				150-159	Color System Reset
				160-169	Gobo Wheel Reset
				170-179	Reserved
				180-189	Focus/Prism /Zoom/Frst Reset
190-199	Reserved				
200-209	Total Reset				
210-255	Reserved				

Remarks:

1. Fan error can cause lamp-off.
2. Note: "Speed Mode" means Pan and Tilt will move from Point A to Point B at their respective maximum speeds."Time Mode" means both Pan and Tilt will arrive at designated point at the same time. It's advised Time Mode be used if the projector runs circles or in oblique lines.









8. ERROR MESSAGES

The system can detect some errors during the reset, if  displayed, touch  to view the error.
The error messages are as follows:

Name	Type	Correction
Pan	Timeout/magnet Sensor/Encoder	Check if wiring, positioning parts and motors are normal
Tilt	Timeout/magnet Sensor/Encoder	Check if wiring, positioning parts and motors are normal
Cyan	Timeout/magnet Sensor	Check if wiring, positioning parts and motors are normal
Yellow	Timeout/magnet Sensor	Check if wiring, positioning parts and motors are normal
Magenta	Timeout/magnet Sensor	Check if wiring, positioning parts and motors are normal
Color Wheel	Timeout/magnet Sensor	Check if wiring, positioning parts and motors are normal
Fixed gobo wheel	Timeout/magnet Sensor	Check if wiring, positioning parts and motors are normal
Rot. Gobo Wheel	Timeout/magnet Sensor	Check if wiring, positioning parts and motors are normal
Rot. Gobo Rotation	Timeout/magnet Sensor	Check if wiring, positioning parts and motors are normal
Dimmer	Timeout/magnet Sensor	Check if wiring, positioning parts and motors are normal

Prism	Timeout/magnet Sensor	Check if wiring, positioning parts and motors are normal
Prism Rotation	Timeout/magnet Sensor	Check if wiring, positioning parts and motors are normal
Focus	Timeout/magnet Sensor	Check if wiring, positioning parts and motors are normal
Zoom	Timeout	Check if wiring, positioning parts and motors are normal
Fan	Error	Check if fan and its wiring are normal
Pan Board	Error	Check signal wire
Tilt Board	Error	Check signal wire
Motor Driver Board 1	Error	Check signal wire
Motor Driver Board 2	Error	Check signal wire
Light source driver board		
Acceleration Sensor	Error	Check signal wire
Lamp on	Timeout	Check if the lamp is damaged
Lamp Life	Timeout Warning	
Lamp Off[Fan Error]	Error	Check if all fans are normal
Time IC	Error	

9. SIGNS OF THE TOUCH SCREEN

	Error Messages		Option Settings
	Address		Information
	Reset		Service
	Config Settings		Operation Mode
	User Memories		

10. TECHNICAL DATA

Electric parameters

Input voltage: 100V~240V AC, 50/60Hz

Power consumption: 420W @ 220V

Rated current: 2.0A/220V

Power factor: PF>0.9

Light sources

Light sources: 260W laser module

Color temperature: 9000K

Rated life: 12000hrs

Colors

1 color wheel: 19 colors + open

Macros and bi-directional rainbow effects with variable speeds

CMY color mixing system

Gobo wheels

1 fixed gobo wheel: 30gobos

Shakable at variable speeds and

bi-directional rotation at variable speeds

1 rotating gobo wheel: 12gobos+open

bi-directional rotation at variable speeds

gobo exchangeable. External size: $\Phi 10\text{mm}$ Image size $\Phi 6\text{mm}$

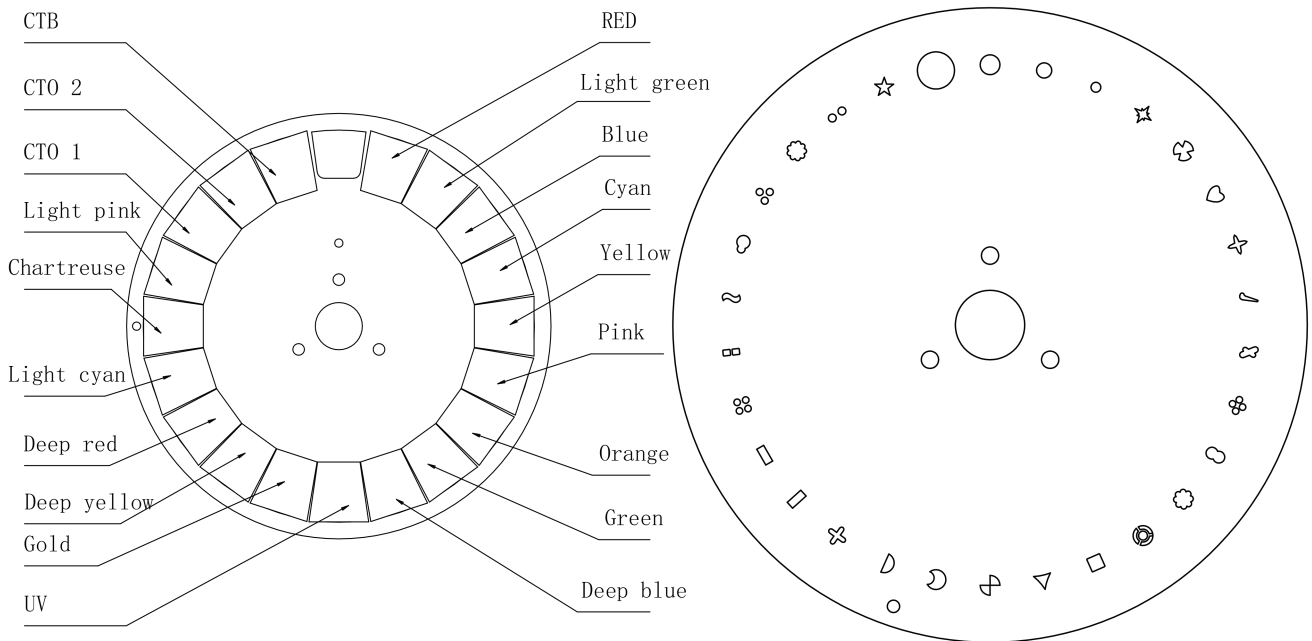

Rotating gobo wheel

Gobo 1	Gobo 2	Gobo 3	Gobo 4	Gobo 5	Gobo 6	Gobo 7
Gobo 8	Gobo 9	Gobo 10	Gobo 11	Gobo 12		

Prism/frost:

2 prism wheels: 1 wheel (an 8-facet circular prism+ a 4-facet linear prism)+1 wheel (a 9-facet circular prism + a gradient prism), prisms can be overlapped. Other prism options available.

Frost

1 pc frost filter

Focus

DMX linear focus

Strobe/Dimmer

Double flag strobe, 0.3-25 F.P.S./ linear dimmer

Movements

Pan (0°-540°), Tilt(0°-270°) with auto positioning correction function

Beam angle

Beam/Spot mode angle: 0.6° -20°

Wash mode : 1.8° -23°

Unique super wide angle: >50°

Control

International standard DMX 512 signal ,5-pin XLR connectors

Short Mode 23 channels, standard Mode 28 channels, extended mode 31 channels

Self test mode

Other functions

Pan and Tilt speeds adjustable

Lamp hours and fixture hours displayed

Modular construction easy for maintenance

Wireless receiver

Wireless transmitter (Optional)

ArtNet control(Optional)

Housing and ingress protection

Cast aluminum and high temperature and UV resistant ABS with IP66

Weight

Net weight: 36.2 Kg

Operation temperature

-20 °C ~ 45 °C

Note: If the ambient temperature is below 0°C, preheat the fixture for some time(less than 20 min based on actual situation normally) before striking the light source

Sizes (unit: mm)

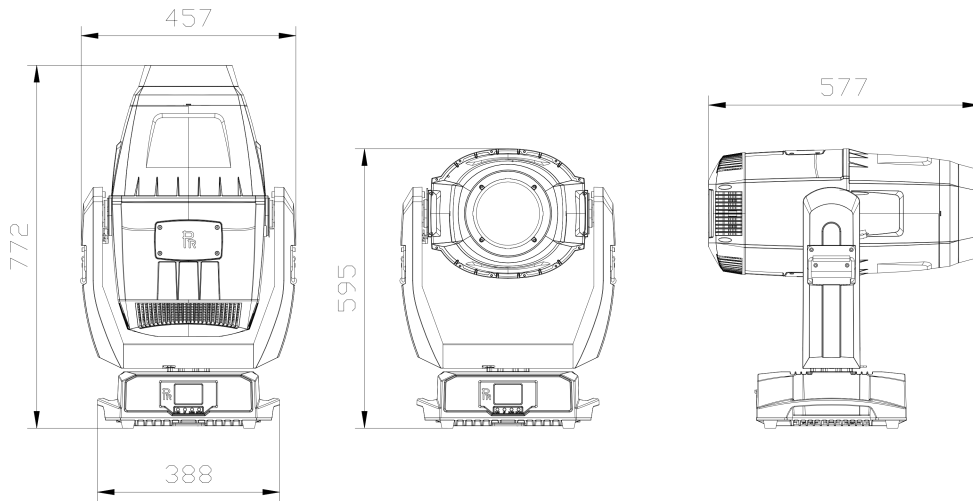

Base installation and its sizes: (unit: mm)

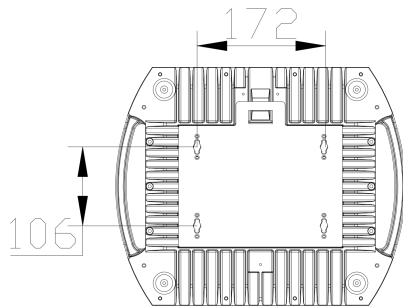

Light output

Beam/Spot Mode

20 °FLUX (lux)	7939	1985	882	496	318	221
0.6 °FLUX (lux)	5440000	1360000	604444	340000	217600	151111

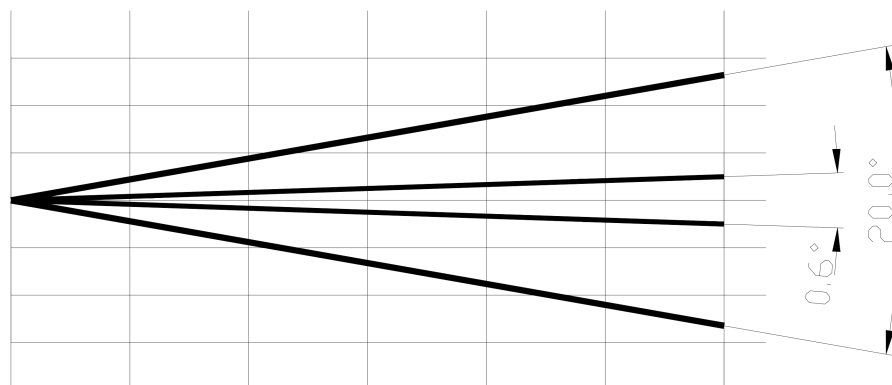

DISTANCE (m)	5m	10m	15m	20m	25m	30m
0.6° DIAMETER (m)	∅ 0.06	∅ 0.11	∅ 0.17	∅ 0.22	∅ 0.28	∅ 0.33
20° DIAMETER (m)	∅ 1.73	∅ 3.46	∅ 5.19	∅ 6.92	∅ 8.65	∅ 10.38

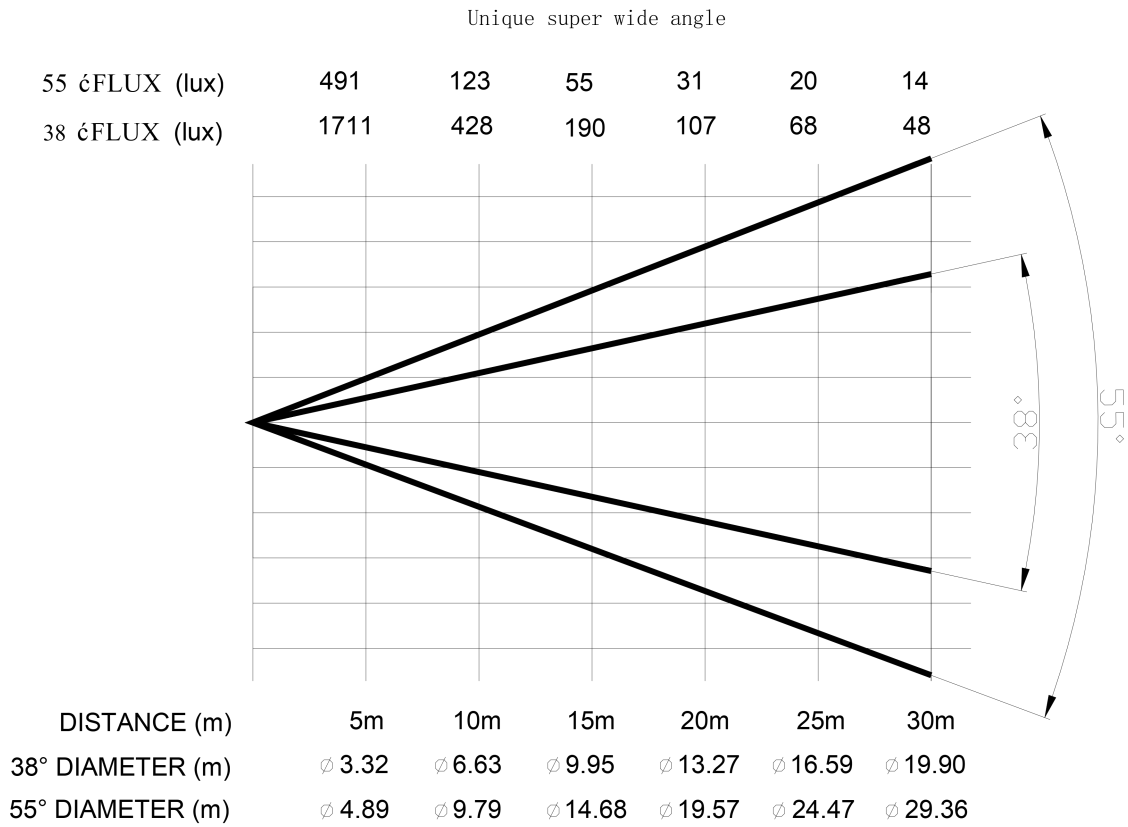
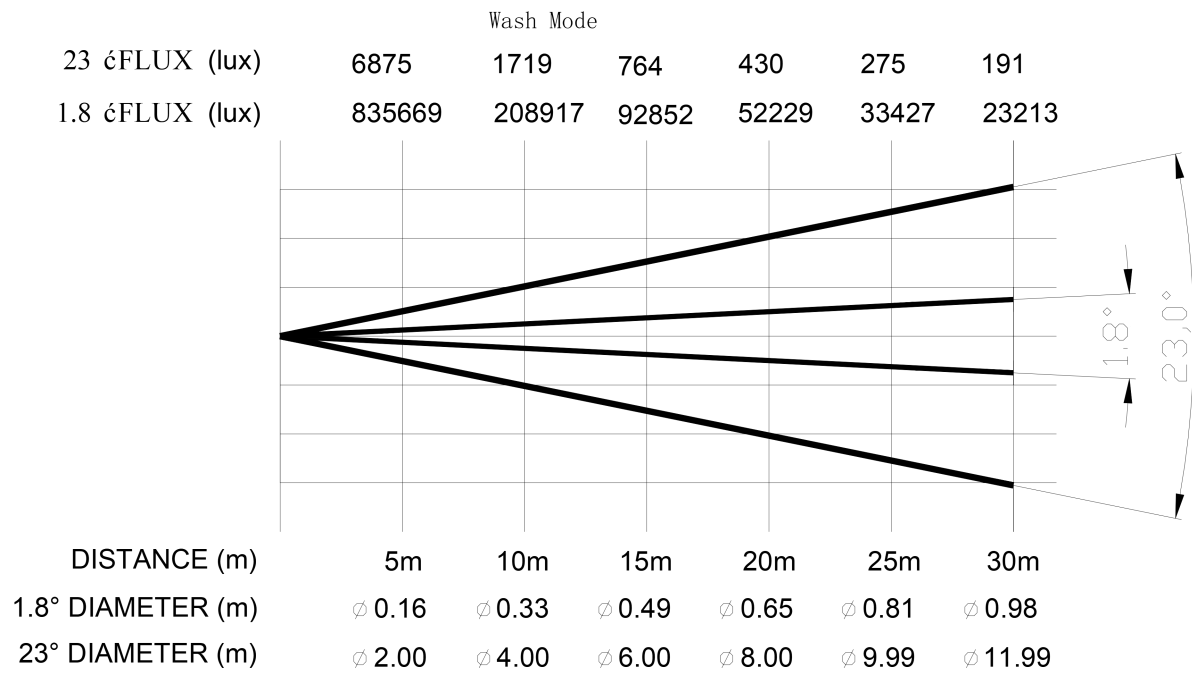

11. CIRCUIT DIAGRAM

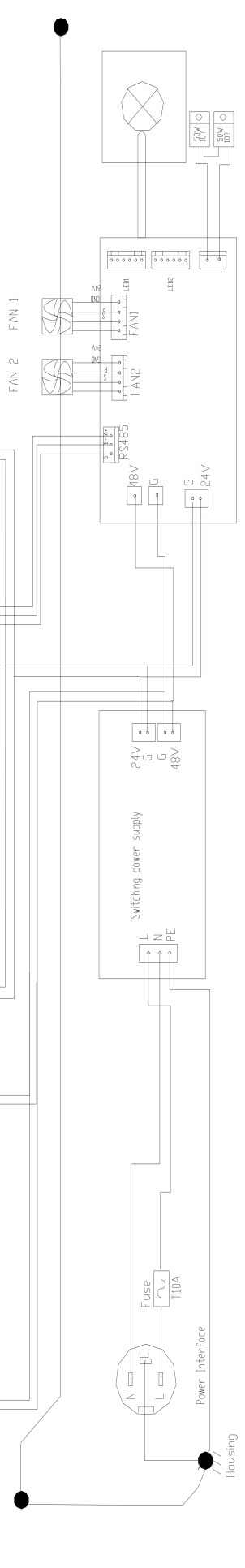
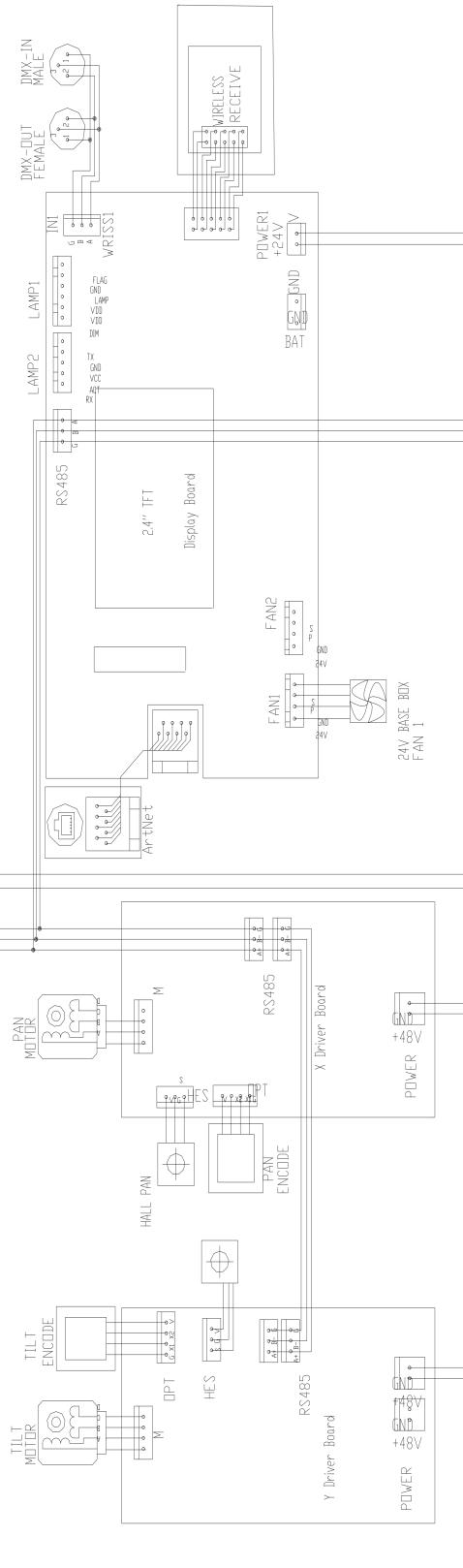
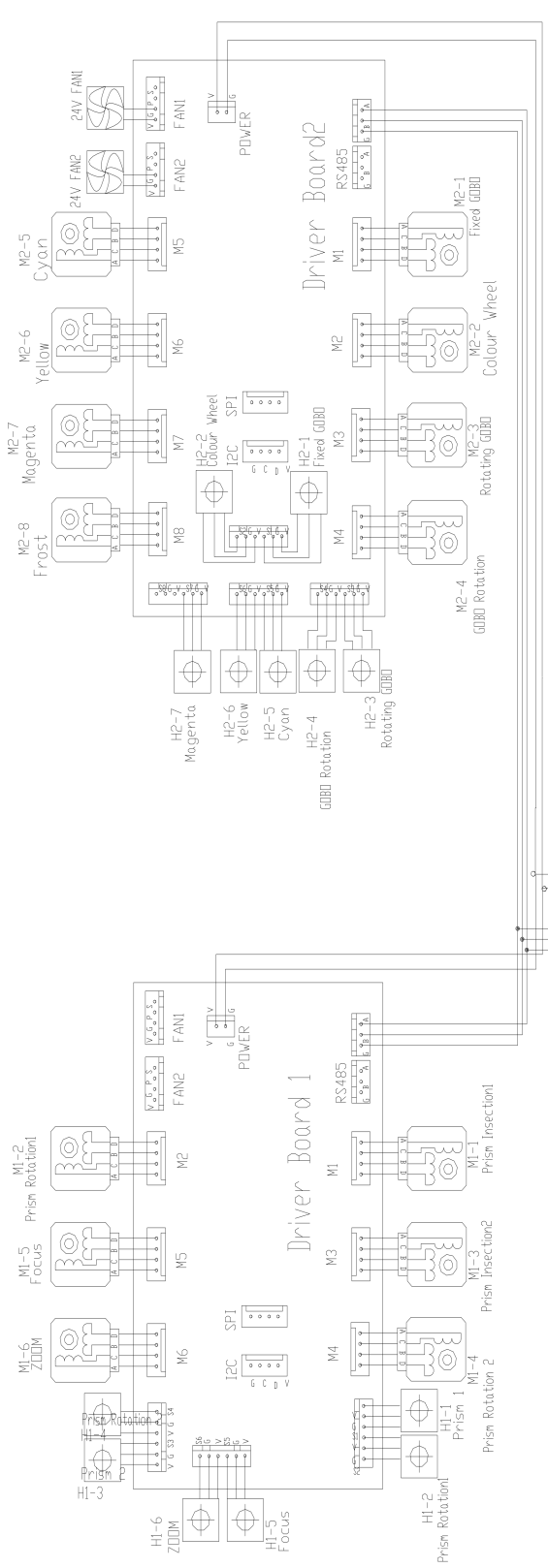

12. COMPONENT ORDER CODES

NO	NAME	CODE NUMBER	QTY
SWITCHING POWER SUPPLY	6190000017	1	
LIGHT SOURCE	150020339	1	
HEAD FAN	030060116	1	
CHAMBER FAN	030060052A	1	
LENS FAN	030060075	1	
LIGHT SOURCE FAN	030060121	1	
BASE FAN	030060075	1	
TILT BELT	030040246B	1	
PAN BELT	030040278B	1	
FOCUS MOTOR	030040243A	2	
FIXED GOBO WHEEL MOTOR	030040221C	1	
COLOR WHEEL MOTOR	030040221C	1	
PRISM IN/OUT MOTOR	030040221C	2	
PRISM ROTATION MOTOR	030040254	2	

PR LIGHTING LTD.

1582 Xingye Avenue, Nancun Panyu
Guangzhou, 511442 China
TEL: +86-20-3995 2888

PR lighting will try its best to offer accurate and overall information about a product's technical data. Any changes won't be notified if necessary. Patented Products.
Counterfeiting Will be Prosecuted!

P/N: 320021562A
Version: 20260319