

AQUA 480 BWS

PR-2497

The user manual contains important information about the safe installation and use of a projector. Please read and follow these instructions carefully and keep the manual in a safe place for future reference.

PR LIGHTING LTD.
<http://www.pr-lighting.com>

INDEX

1.	SAFETY AND WARNINGS.....	3
2.	INSTRUCTIONS.....	4
3.	APPEARANCE.....	5
4.	INSTALLATION	6
5.	SETUP AND CONFIGURATION.....	9
6.	OPERATION MENU.....	10
7.	DMX PROTOCOL.....	15
8.	SIGNS ON THE TOUCH SCREEN.....	19
9.	ERROR MESSAGES.....	19
10.	TECHNICAL DATA.....	21
11.	CIRCUIT DIAGRAM.....	25
12.	COMPONENT ORDER CODES.....	26
	APPENDIX.....	27

ACCESSORIES

The following items are supplied with the projector and please check:

Name	Quantity	Unit	Remark
G clamps	2	Pcs	
XLR connector	1	Set	Male and female
Safety cord	1	Pc	
User manual	1	Pc	
Ω clamps	2	Pcs	Optional

Please note that as part of our ongoing commitment to continuous product development, specifications are subject to change without notice. Whilst every care is taken in the preparation of the manual we reserve the right to change specifications in the course of product improvement. The publishers cannot be held responsible for the accuracy of the information herein, or any consequence arising from them.

Every unit is tested completely and packed properly by the manufacturer. Please make sure the packing and / or the unit are in good condition before installation and use. Should there be any damage caused by transportation, consult your dealer and do not use the unit. Any damage caused by improper use will not be assumed by the manufacturer and / or dealer.

Note: For the products made by Guangzhou PR lighting Ltd, the warranty for the whole product is one year starting from the delivery date but the light source is not within the warranty.







1.SAFETY AND WARNINGS



NOTE

Before a projector's installation, power-on, operation and maintenance, please carefully read the safety information hereinafter!

The following safety signs are used in the user manual.

						
Warning	User Manual	Electrical shock	Goggles	Protective Gloves	Flames	High Temperature



- When unpacking , check if there is transportation damage before using the projector. Should there be any damage caused by transportation, consult your dealer and do not use it.
- The manufacture is not responsible for loss caused by the user not following the manual or changing the projector as he/she likes.
- Please be noted that the damage caused by changing the projector at will is not warranted.
- Do not hesitate to contact the dealer or the manufacturer if any questions or advice.



- The projector is for indoor and outdoor use, IP66.
- It can be used in humid and dusty areas. And it can contact water and other non-corrosive liquids.
- The projector should be kept away from high temperature, fire, electrical surge, vibration and strong light while being operated
- The projector is only intended for installation, operation and maintenance by qualified personnel. And the operation must strictly follow the procedures in the manual
- No repairable parts in the projector and do not open covers for maintenance by yourself.



- Don't look straightly into the light sources especially for epileptics, otherwise eyes will be burned.
- Do not connect this device to any type of dimmer pack.
- After lamp switched on, the minimum distance between the projector and illuminated surface is 18m.
- lens and other optical parts shall be replaced immediately if they have deformed or been damaged, otherwise the light output will be compromised.



- Before operation, please confirm that all covers(housing) are on and screws tightened. It's forbidden to use a projector while covers(housing)are off .
- Keep the lamp clean and do not touch it with bare hands.
- While operating it, wear protective items.



- Any electrical connection must be carried out by a qualified person .
- Before installation, please confirm the voltage supplied matches what is required for the projector.
- Each projector must be properly earthed and installed as per related electrical standards.
- Do not use power cord with its insulator damaged and connect the power cord with other cables.
- If the projector is not used or under cleaning,, please hold the plug and unplug it. Do not unplug it forcefully or by pulling the power cable.
- All power cords must conform to related safety and regulations.
- While being operated, the projector should not be under rains or in humidity.
- Do not switch on and off the projector constantly in very short intervals, otherwise the light source's and other electrical parts' life will be shortened .



- There are safety cord holes at the bottom of the base of a projector. In view of safety, please run the safety cord supplied through the safety cord holes for safety support.
- Before any installation, maintenance and cleaning work, please ensure the projector is disconnected from power mains.



- After running for 30minutes, the temperature of the housing of the projector is 45°C. After stable operation, its temperature is 75°C.
- While the lamp is stricken for the first time, there will be smoke and strange smell. It's normal and does not mean the projector has some defects.



- Do not mount the projector directly on inflammable surface.
- Do not project the beam straightly on combustible items and the minimum distance between the projector and illuminated items is 18m.
- A projector should be installed with good ventilation and the minimum distance between the projector and walls is 50cm. At the same time, please ensure the fans and air inlets and outlets are workable.

2. INSTRUCTIONS

•CLEANING AND MAINTENANCE

If a projector can't start. Please check if the fuse is blown up. If it does, replace it with a new fuse with same ratings. And the projector has over-temperature protective device. If the temperature is too high, the protective device will be triggered to shut the projector off. When it happens, please check if the fans run normally or fan shield is blocked by dust. After the issue is solved, restart the projector.

The accumulation of oil, smoke and dust on the lens will compromise the light output. Cleaning a projector is very necessary to ensure a reliable use of it. Cooling fans need to be cleaned every 15days. Internal lens, reflector and hot mirror need to be cleaned periodically to optimize light output.

Cleaning frequency is to be decided by operations and its environment. Use soft cloth and normal detergent for glass for cleaning work. It's advised external optical system be cleaned every 20days and internal optical systems every 30/60days. Keep lens clean and do not touch optical parts with bare hands.

Special note:

It's normal phenomena that there will be mild water mist on the lens while the waterproof product is in use.



- Before any maintenance and cleaning, please ensure the project is off the power.
- Only qualified person is allowed to do maintenance.
- During maintenance and before maintenance, the projector must be off power.



- To avoid the sunlight or other light beam penetrates through the front lens into the head, which results in high temperature internally and damaging the projector accordingly. Before power-ff, please use the Tilt channel to let the head face down.**
- Do not use alcohol or other organic solvent to clean the housing to avoid damage.
- Do not use any solvent with chemical elements to clean color filters or hot mirror.

•LUBRICATION

To ensure smooth movement of gobos and zoom and focus lens, it's advised rotators' bearings and 2 sliding bars for zoom and focus lens be lubricated every 2 months. High quality and high temperature lubricant/grease is advised.

•TROUBLESHOOTING

PROBLEM	ACTION
The projector doesn't switch on	<ul style="list-style-type: none"> ➤ Check the fuse on the power socket. ➤ Check the lamp.
The lamp is on but the projector doesn't respond to the controller	<ul style="list-style-type: none"> ➤ Make sure that the fixture's start address is right ➤ Replace or repair the XLR signal cable.
The projector functions intermittently	<ul style="list-style-type: none"> ➤ Make sure the fan is working well or fans and their shields are not blocked
Beam appears dim, Low in brightness	<ul style="list-style-type: none"> ➤ Make sure the lamp is within its lifespan ➤ Remove dust or grease from the lenses.
The project image appears to have a halo	<ul style="list-style-type: none"> ➤ Carefully clean the lamp, optical lenses and other components.
Heavily Defective Beam	<ul style="list-style-type: none"> ➤ Check if lens are in good condition(not cracked) ➤ Clean dust or grease on the lens.

3.APPEARANCE

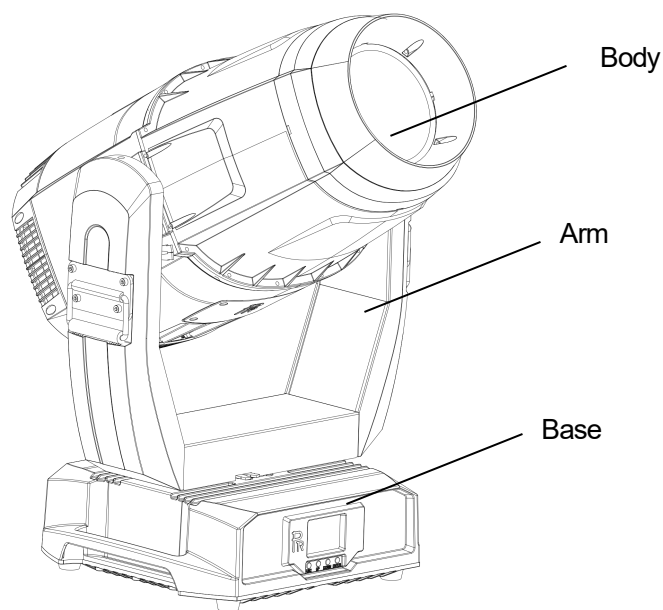

4.INSTALLATION

•RIGGING

Before moving a projector, Please lock Pan and Tilt. Before its operation, please unlock them. It's forbidden to run a projector with power while it is locked.

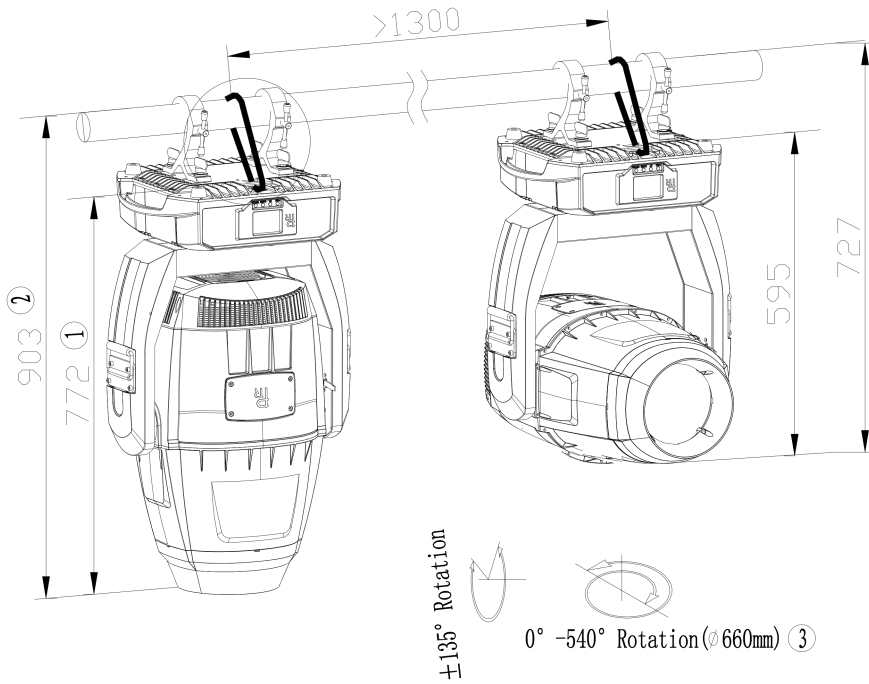

Note:

1. the distance between the foot of the base and the front lens cover (the head facing downward)
2. the distance between mounting truss and the front lens cover (the head facing downward)
3. The maximum diameter of the rotating head (minimum spacing between fixtures)

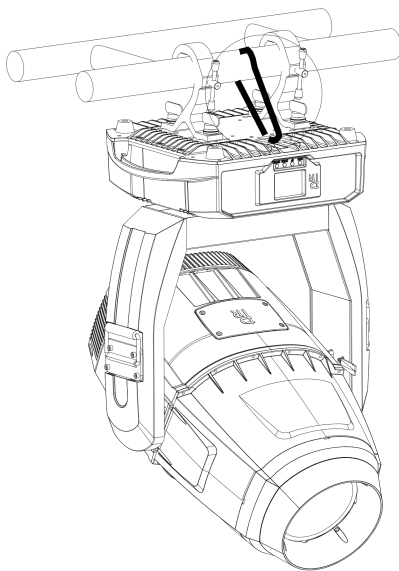

Warning!

For safety, please run the safety cord through its hole.

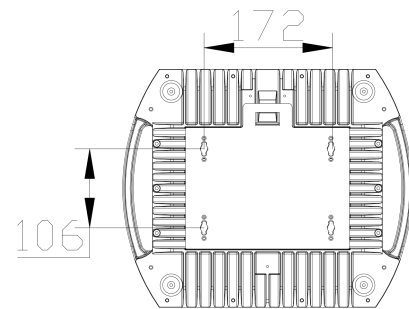
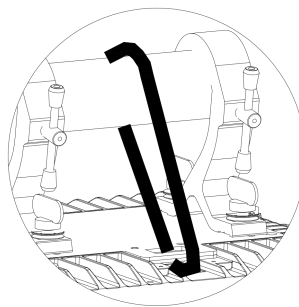

Take 2 clamps and the safety cord out from the package and mount 2 clamps on the underside of fixture with 2 retainers attached to each clamp. Hang the fixture on the structure and fasten the screws attached to each clamp. (See the **WARNING** on the underside of the base as shown above) **To pass the SAFETY CORD through the HOLES for safety!** Always ensure that the projector is firmly anchored to avoid vibration and slipping whilst functioning. Always ensure that the structure that you are going to mount the projector to is secure and strong enough to support the weight of a XR 1000 Framing.



WARNING:

- The projector **MUST** be lifted or carried by the **HANDLES** instead of clamps.
- For safety the safety cord should afford 10 times the Projector's weight.

• **POWER CONNECTION**

Connect the power cord as follows:

- L (live) =brown
- E (earth) =yellow/green
- N (neutral) =blue

Before power connection, please ensure the power supplied must match what the nameplate says. It is recommended that each projector be connected with power separately so that they may be individually switched on and off.



- The earth wire(yellow/green) must be connected to the ground. And electrical connection must be in accordance with the standards concerned.
- If any questions about the electrical installation, do not continue but consult a qualified electrician.

DMX CONTROL CONNECTION:

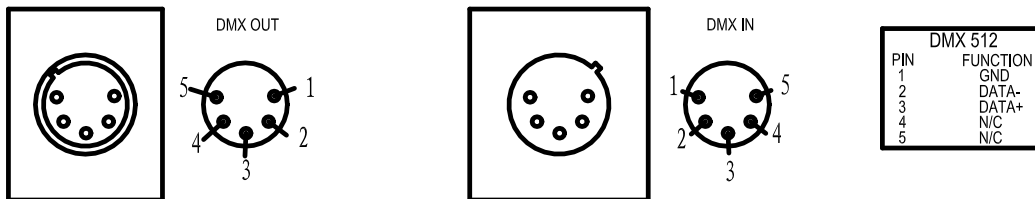

Connection between controller and projector and between one projector and another must be made with a twin-screened cable, with each wire having at least a 0.5mm in diameter. Connection to and from the projector is via cannon 5 pin (which are included with the projector) or 5 pin XLR plugs and sockets. The XLR's are connected as shown in the figure above.

Note: care should be taken to ensure that none of the pins touch the metallic body of the plug or each other. XLR plugs and sockets mustn't be connected in any way other than mentioned in the above figure. The Fixture accepts digital control signals in protocol DMX512 (1990).

Connect the controller's DMX output to the first fixture's DMX input, and connect the first fixture's DMX output to the second fixture's DMX input and connect the rest fixtures in the same way. Eventually connect the last fixture's DMX output to a DMX terminator as shown in the figure below.

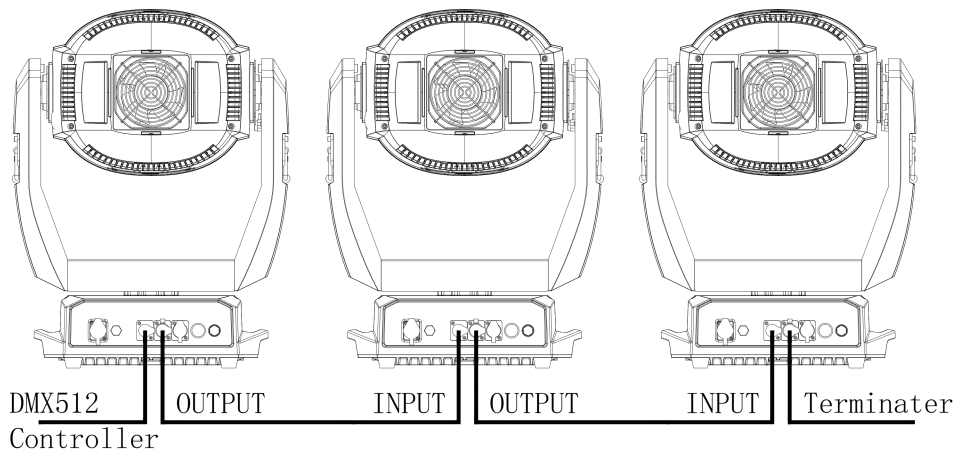

DMX TERMINATOR

In the Controller mode, at the last fixture in the chain, the DMX output has to be connected with a DMX terminator. This prevents electrical noise from disturbing and corrupting the DMX control signals.

The DMX terminator is simply an XLR connector with a 120Ω (ohm) resistor connected across pins 2 and 3, which is then plugged into the output socket on the last projector in the chain. The connections are illustrated below.

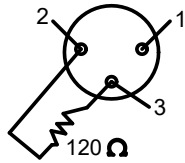

**DMX TERMINATOR
CONNECTION**

Connect a 120Ω(OHM) resistor
across pins 2 and 3 in an XLR plug
and insert into the DMX out socket
on the last unit in the chain.

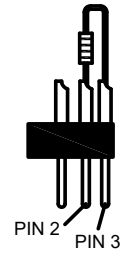

ALIGNMENT/INSTALLATION/REPLACEMENT OF A LAMP

Please hold the projector well before adjustment/installation/replacement of lamp. As shown in figure1, remove fan cover of the head and heat sink.

Removal/Installation of lamp as shown in figure2

Adjust the lamp as shown in figure3

Before the removal of the lamp, unplug the lamp wires. And plug lamp wires after a new one is in.



- Don't touch the internal surface of the reflector and the burner of the lamp with bare hands so as not to impair the beam output. There is a protruding metal wire in the lamp, while installation do not damage it. Hold the lamp body well before its removal. It's forbidden to use force on the ceramic stand, otherwise it will loosen or fall off.
- Please read "Instructions " enclosed with the lamp
- While adjusting the lamp, it is forbidden to carry out the functions not associated with lamp adjustment.

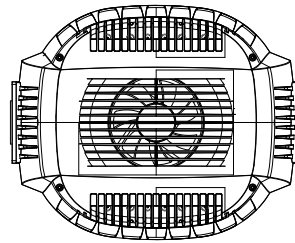
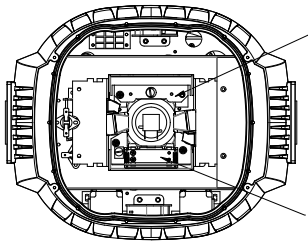
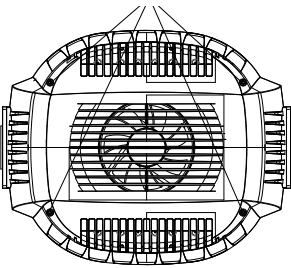

Figure1: loosen 4 screws of the fan cover of the head before removing it. Then loosen the screws of heat sink and remove it and the fan.

Figure2: Unplug the lamp wires , push the upper clipping plate toward the spring with force, but push the lamp in the opposite direction till it is off the plate, then take the lamp out obliquely. The same applies to its installation.

Figure 3: After the replacement of the lamp, please ensure first the lamp is clipped well before plugging lamp wires. Turn the lamp on and adjust the lamp's position to the middle. After that, install the heat sink, fan and fan cover.

1. After the projector is powered on, disable the following function in the menu: services-factory mode- lamp fan sensor , then shut it from power
2. Loosen the 4 screws of the fan cover and remove it.
3. Loosen 4 screws of the fan plate, remove the fan and the clump weight, loosen 10 screws of the heat sink and remove it.
4. Push the upper clipping plate of the lamp towards the spring, and at the same time pus the lamp towards the opposite till it is off the plate and remove it obliquely,
5. The installation of the lamp is the same as its removal
6. Check if the lamp wires are plugged well, then turn on the lamp for adjustment
7. After the adjustment of the lamp, activate the following function in the menu: services-factory mode- lamp fan sensor. Then shut it from the power
8. Check if the seals are good or not. If not, replace them with good ones. If no, install the heat sink, fan and fan cover in the opposite sequences as the removal.
9. After installation, power it on. The projector will execute the total reset. After that, the projector can be used normally.



Note: There is some delay in lamp-striking of a projector which is caused by the lamp itself and it is normal.

•GOBO REPLACEMENT

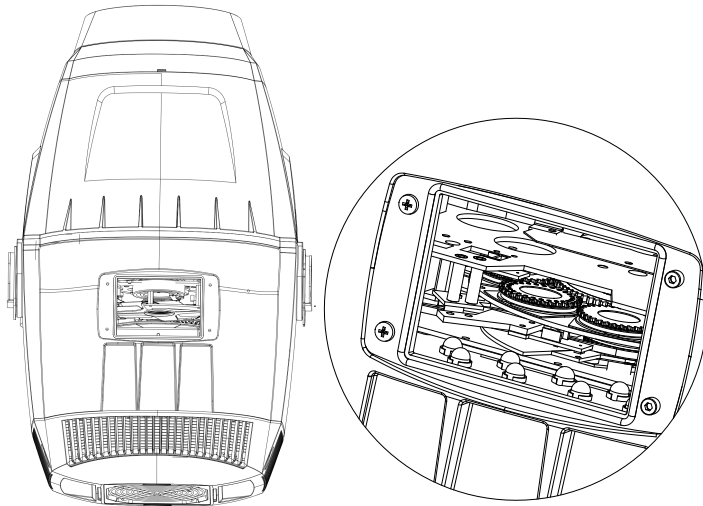

Replacement of the Gobos:
 Open the chamber cover after loosening 4 screws. Select the rotator for replacement of gobo. Push the rotator at the opposite side of its gear till it is off the holder of the rotating gobo wheel. Remove the rotator gently. After replacement of the gobo, place the rotator into the wheel and ensure it is in the right position and not loose.

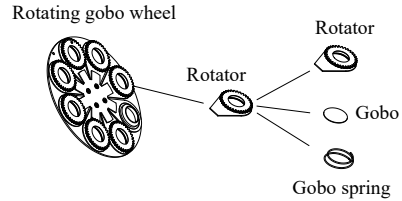

DANGER!

Before replacement of gobos, the projector must be off the power.

5. SETUP AND CONFIGURATION
•FRONT PANEL OPERATION

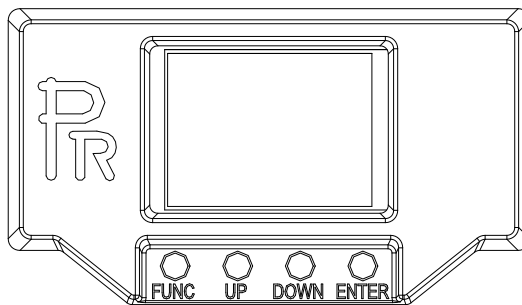

To browse through or change the projector's settings, press ENTER key for more than 3s (press ENTER key after power on) to unlock the screen, then press UP/DOWN key to enter the projector's function menus. Each main menu has its sub-menus. And each menu stands for special function. For the details, please see the following 6th point "Operation Menu".:

1. At the page to set the fixture's functions, press **UP** or **DOWN** key to select the functions desired.
2. While menu operations, the **FUNC** key to escape, and **ENTER** key is used to confirm. Press **ENTER** key to save the changes or enter into the sub menus. Press **UP** or **DOWN** key to change the numbers (minus or plus).

Press FUNC key to go to the uppler menu. If no key is pushed, the system will go back to initial status automatically.

• DMX START ADDRESS

Each projector must be given a DMX start address so that the correct projector responds to the correct control signals. This DMX start address is the channel number from which the projector starts to "listen" to the digital control information being sent out from the controller. The projector has 3DMX modes. There are standard mode, short mode and extended mode. For example standard mode has 31 channels, so set the No. 1 projector's address 001, No. 2 projector's address 032, No. 3 projector's address 063, No. 4 projector's address 094, and so on.

Switch on the Projector. Press **ENTER** key more than 3 seconds to unlock panel, then press **UP** or **DOWN** key to enter into the fixture's operation menus.

Select DMX Address icon and press ENTER key on the display and select DMX address at the 2nd level menu for the address setting.

Press **UP** or **DOWN** key for the DMX address desired.
 Press **ENTER** key to confirm.
 Press the **FUNC** key to go back to the upper level menu.

•DMX WIRELESS CONTROL

The projector has wireless control function with wireless receiver module and antenna for remote control.
 The setup of it is below:

1. Press **ENTER** for more than 3s to unlock the control panel, then press **UP** or **DOWN** key to enter into the operation menu and select “Config Settings”.
 2. Select “Wireless Only” from the menu of “Signal Select”.
- Only after the projector is linked with a transmitter, can it receive wireless signal sent by the transmitter. If unlinking it, Press “Enter” for the menu of Un-link Wireless under the upper level menu of Config Settings , then the fixture is unlinked with the wireless transmitter.

•STAND-ALONE MODE

Operate the projector without connecting with a controller, enable the master mode through the operation panel, the projector will run in Stand-Alone mode automatically.
 DMX address can be set at any number within 512.

•MASTER/SLAVE MODE

Many projectors can run synchronously in the Master/Slave mode by linking them with each other. First, connect the first fixture’s DMX output to the second fixture’s DMX input using XLR-XLR control cable and then connect the second fixture’s DMX output to the third fixture’s DMX input, and so on until all projector are connected in this way. Eventually connect the last fixture’s DMX output to a DMX terminator. Set 1st projector as the master and others are Slaves.

Start Addresses of all Slaves are 001; Operation mode of the Master can be set any mode for a Master’ and Slaves’ operation mode can be set accordingly.

After Powered on, the group will run in Master/Slave Mode

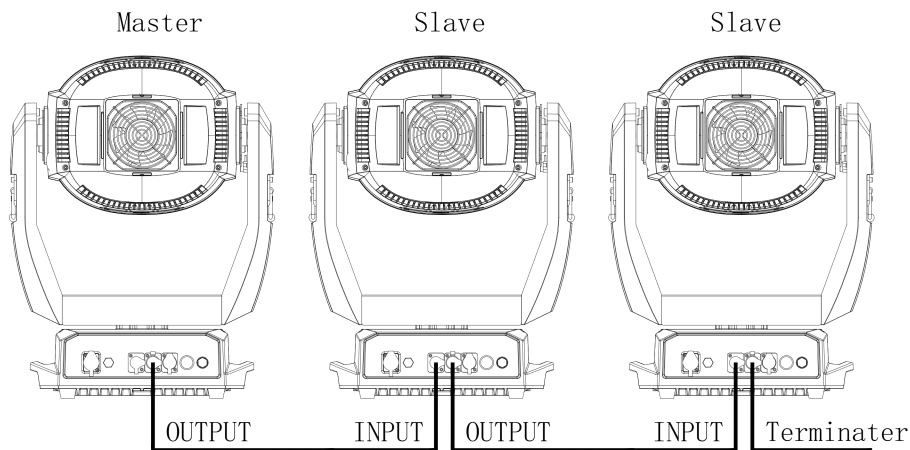

6.OPERATION MENU

1st LEVEL	2nd LEVEL	3rd LEVEL	4th LEVEL	5th LEVEL
Address	DMX Address	1-512		
	IP Address	Default IP Address	2.X.X.X/10.X.X.X	
		Custom IP Address	X.X.X.X	
	SubNet Mask	X.X.X.X		
	ArtNet Universe	0-255		
Reset	Total Reset	Really Reset?		

		Confirm or Cancel			
	Pan&Tilt Reset	Really Reset? Confirm or Cancel			
	Colour System Reset	Really Reset? Confirm or Cancel			
	Gobo Reset	Really Reset? Confirm or Cancel			
	Dimmer/Shutter reset	Really Reset? Confirm or Cancel			
	Zo.Fo. Fr. Pr. Reset	Really Reset? Confirm or Cancel			
Config Settings	DMX Channel Mode	Short Mode			
		Standard Mode			
		Extended Mode			
		View Selected Mode	Ch.01 Strobe Ch.02 Dimmer Ch.23 Control Function		
	Lamp Control	Lamp Control	OFF/ ON		
		On By Power On	OFF/ ON		
		Control By DMX	OFF/ ON		
		Eco Power	OFF/ ON		
	Signal Select	XLR Only			
		XLR First			
		Wireless Only			
		Wireless First			
		Wireless In/XLR Out			
		ARTNET Only			
		ARTNET In/XLR Out			
		sACN Only			
	Loss of DMX	Normal time out			
		Hold Last Value			
	Display Config	Display Mode	Off After Delay		
			On Always		
		Display Invert	Invert OFF		
			Invert ON		
			Invert Auto		
		Language Setting	English/Chinese		
	Screen Calibration	XXX			
	Temperature Unit	Celsius Degree			
		Fahrenheit Degree			
Un-Link Wireless	Really Un-Link? Confirm or Cancel				
Defaults	Restore Defaults? Confirm or Cancel				
Option Settings	Pan/Tilt Settings	Pan DMX Invert	OFF/ ON		
		Tilt DMX Invert	OFF/ ON		
		Pan Tilt Swap	OFF/ ON		
		XY Feedback	OFF/ ON		
		Pan/Tilt mode	Speed/Time	Note: "Speed Mode" means Pan and Tilt will move from Point A to Point B at their	

				respective maximum speeds."Time Mode" means both Pan and Tilt will arrive at designated point at the same time. It's advised Time Mode be used if the projector runs circles or in oblique lines.
	Invert Settings	Dimmer Invert	OFF/ON	
		Zoom Invert	OFF/ON	
		CYM Invert	OFF/ON	
Information	View DMX Values	Channel Value		
		Strobe XXX		
		Dimmer XXX		
		Dimmer Fine XXX		
		CYM Macro XXX		
		Cyan XXX		
		Yellow XXX		
		Magenta XXX		
		CTO XXX		
		Color Wheel XXX		
Color Wheel Fine XXX				
Fixed Gobo Wheel XXX				
Rot. Gobo Wheel XXX				
Rot. Gobo Rotation XXX				
Rot. Gobo Rotation F. XXX				
Effect XXX				
Effect Rotation XXX				
Prism1 XXX				
Prism1 Rotation XXX				
Prism2 XXX				
Prism2 Rotation XXX				
Frost XXX				
Focus XXX				
Focus Fine XXX				
Zoom XXX				
Zoom Fine XXX				
Pan XXX				
Tilt XXX				
Pan/Tilt Speed & Time XXX				
Power/Special Fun. XXX				
	Lamp Hours	XXX H Reset Lamp Hours		
	Total Hours	xxxxH		
	Temperature	Display Board=xxx°C Pan board=xxx°C Tilt board=xxx°C Driver Board1=xxx°C Driver Board2=xxx°C Driver Board3=xxx°C Head Sensor=xxx°C		
	Software Version	PCB Sys Boot Display Board xxx xxx Pan board xxx xxx Tilt board xxx xxx Driver Board1 xxx xxx Driver Board2 xxx xxx Driver Board3 xxx xxx		
	Electronic SN	XXXXXX		
	RDM Device Label	***** ANSI E1.20 RDM		
	Fan Status	Fan Speed Status Lamp Fan1 xxx on/off		

		Lamp Fan2 xxx on/off Strobe Fan xxx on/off Gobo Fan xxx on/off Lamp T Fan xxx on/off Lamp R Fan2 xxx on/off Head Fan xxx on/off		
Service	Manual Effect Control	Strobe XXX		
		Dimmer XXX		
		CYM Macro XXX		
		Cyan XXX		
		Cyan Fine XXX		
		Yellow XXX		
		Yellow Fine XXX		
		Magenta XXX		
		Magenta Fine XXX		
		CTO XXX		
		CTO Fine XXX		
		Color Wheel XXX		
		Color Wheel Fine XXX		
		Fixed Gobo Wheel XXX		
		Rot. Gobo Wheel 1 XXX		
		Rot. Gobo1Rotation XXX		
		Rot. Gobo1Rotation F. XXX		
		Effect Wheel Rotation XXX		
		Effect Wheel RotationFine XXX		
		Prism 1 XXX		
		Prism 1 Rotation XXX		
		Prism 2XXX		
		Prism 2 Rotation XXX		
		Focus XXX		
		Focus Fine XXX		
		Zoom XXX		
		Zoom Fine XXX		
		Pan XXX		
		Pan Fine XXX		
		Tile XXX		
		Tilt Fine XXX		
		Pan & Tilt Speed & Time XXX		
	Control Function XXX			
	Factory Mode	XXX		
Operation Mode	DMX Mode	Change Operation Mode? Confirm or Cancel		
	Master Mode	Preset Memory	Change Operation Mode? Confirm or Cancel	
		User Memory 1	Change Operation Mode? Confirm or Cancel	
		User Memory 2	Change Operation Mode? Confirm or Cancel	
	Stand-Alone Mode	Preset Memory	Change Operation Mode? Confirm or Cancel	
		User Memory 1	Change Operation Mode? Confirm or Cancel	
		User Memory 2	Change Operation Mode?	

			Confirm or Cancel	
	Static Scene	Change Operation Mode? Confirm or Cancel		
User Memories	Edit User Memory	Edit User Memory 1 / Edit User Memory 2	(1~200Scenes) Scene XX (1~200 Scenes)	Strobe XXX
				Dimmer XXX
				Dimmer Fine XXX
				CYM Macro XXX
				Cyan XXX
				Cyan Fine XXX
				Yellow XXX
				Yellow Fine XXX
				Magenta XXX
				Magenta Fine XXX
				CTO XXX
				CTO Fine XXX
				Color Wheel XXX
				Color Wheel Fine XXX
				Fixed Gobo Wheel XXX
				Rot. Gobo Wheel 1 XXX
				Rot. Gobo 1 Rotation XXX
				Rot. Gobo 1 Rotation F. XXX
				Effect Wheel Rotation XXX
				Effect Wheel Rotation Fine XXX
				Prism 1 XXX
				Prism 1 Rotation XXX
				Prism 2 XXX
				Prism 2 Rotation XXX
				Focus XXX
				Focus Fine XXX
				Zoom XXX
				Zoom Fine XXX
				Pan XXX
				Pan Fine XXX
		Tile XXX		
		Tilt Fine XXX		
		Pan & Tilt Speed & Time XXX		
Control Fun. XXX				
Delay Time XXX				
Delay time unit msec/s/m				
Link to Step XXX				
		Edit Static Scene		Strobe XXX
				Dimmer XXX
				Dimmer Fine XXX
				CYM Macro XXX
				Cyan XXX
				Cyan Fine XXX
				Yellow XXX
				Yellow Fine XXX

			Magenta XXX	
			Magenta Fine XXX	
			CTO XXX	
			CTO Fine XXX	
			Color Wheel XXX	
			Color Wheel Fine XXX	
			Fixed Gobo Wheel XXX	
			Rot. Gobo Wheel 1 XXX	
			Rot. Gobo 1 Rotation XXX	
			Rot. Gobo 1 Rotation F. XXX	
			Effect Wheel Rotation XXX	
			Effect Wheel Rotation Fine XXX	
			Prism 1 XXX	
			Prism 1 Rotation XXX	
			Prism 2 XXX	
			Prism 2 Rotation XXX	
			Focus XXX	
			Focus Fine XXX	
			Zoom XXX	
			Zoom Fine XXX	
			Pan XXX	
			Pan Fine XXX	
			Tilt XXX	
			Tilt Fine XXX	
			Pan & Tilt Speed & Time XXX	
			Control Function XXX	
	Init User Memory	Reset User Memory 1	Reset User Memory? Confirm or Cancel	
		Reset User Memory 2	Reset User Memory? Confirm or Cancel	
		Reset Static Scene	Reset Static Scene? Confirm or Cancel	

Remarks: Lamp fan sensor is only used during lamp adjustment

Open: the lamp is affected by the lamp fan. If the lamp fan fails, the lamp won't be on.

Close: the lamp is not affected by the lamp fan. Even if the lamp fan is not installed, the lamp will be on, but Pan and Tilt are without force .

“Close” status is used only in emergency. If the lamp fan won't run for long, it will cause harm to the lamp.

After lamp adjustment, set the “lamp fan sensor as “Open” and activate total reset.

7. DMX PROTOCOL

Short mode	Standard mode	Extended Mode	FUNCTION	DMX	DESCRIPTION
1	1	1	Strobe	000-010	Close
				011-025	Open
				026-225	Strobe speed from slow to fast
				226-246	Random strobe from slow to fast
				247-255	Open
2	2	2	Dimmer	000-035	Close
				036-255	Linear dimming (0-100%)

	3	3	Dimmer Fine	000-255	Dimmer in 16 bit
3	4	4	CYM Macro	000-016	White
				017-035	Yellow+ Magenta=Red
				036-054	Yellow
				055-073	Yellow +Cyan=Green
				074-092	Cyan
				093-111	Cyan + Magenta= purple
				112-128	Magenta
				129-255	CYM color mixing from slow to fast
4	5	5	Cyan	000-255	Cyan (linear 0~100%)
		6	Cyan Fine	000-255	Cyan in 16 Bit
5	6	7	Yellow	000-255	Yellow (linear 0~100%)
		8	Yellow Fine	000-255	Yellow in 16 Bit
6	7	9	Magenta	000-255	Magenta (linear 0~100%)
		10	Magenta Fine	000-255	Magenta in 16 Bit
7	8	11	CTO	000-005	No
				006-024	Diffuser
				025-255	Linear CTO
		12	CTO Fine	000-255	CTO in 16 bit
8	9	13	Color Wheel	000-063	Indexing(0-360degrees)
				064-068	Color1(Red)
				069-073	Color2(Light Green)
				074-078	Color3(Blue)
				079-083	Color4(Cyan)
				084-088	Color5(Yellow)
				089-093	Color6(Magenta)
				094-098	Color7(Orange)
				099-103	Color8(Green)
				104-108	Color9(Dark Blue)
				109-113	Color10(UV)
				114-118	Color11(Light Yellow)
				119-123	Color12(Dark Yellow)
				124-127	White
				128-191	Rotation ,Clockwise from slow to fast
192-255	Rotation, Anti-clockwise from fast to slow				
	10	14	Color Wheel Fine	0000-255	Color Wheel in 16 Bit
9	11	15	Fixed Gobo Wheel	000-008	White
				009-015	Gobo1
				016-022	Gobo2
				023-029	Gobo3
				030-036	Gobo4
				037-043	Gobo5
				044-050	Gobo6
				051-059	Gobo7

				060-064	Gobo8
				065-071	Gobo9
				072-078	Gobo10
				079-085	Gobo11
				086-092	Gobo12
				093-099	Gobo13
				100-106	Gobo14
				107-113	Gobo15
				114-120	Gobo16
				121-127	Gobo17
				128-157	Clockwise rotation from slow to fast
				158-187	Anti Clockwise rotation from slow to fast
				188-191	Shake effect 1 from slow to fast
				192-195	Shake effect 2 from slow to fast
				196-199	Shake effect 3 from slow to fast
				200-203	Shake effect 4 from slow to fast
				204-207	Shake effect 5 from slow to fast
				208-211	Shake effect 6 from slow to fast
				212-215	Shake effect 7 from slow to fast
				216-219	Shake effect 8 from slow to fast
				220-223	Shake effect 9 from slow to fast
				224-227	Shake effect 10 from slow to fast
				228-231	Shake effect 11 from slow to fast
				232-235	Shake effect 12 from slow to fast
				236-239	Shake effect 3 from slow to fast
				240-243	Shake effect14 from slow to fast
				244-247	Shake effect 15 from slow to fast
				248-251	Shake effect 16 from slow to fast
				252-255	Shake effect 17 from slow to fast
10	12	16	Rotating Gobo Wheel 1	000-015	White
				016-031	Gobo 1
				032-047	Gobo 2
				048-063	Gobo 3
				064-079	Gobo 4
				080-095	Gobo 5
				096-111	Gobo 6
				112-127	Gobo 7
				128-156	Rotation (clockwise From slow to Fast)
				157-185	Reverse Rotation (anti-clockwise From slow to Fast)
				186-195	Shake of Gobo 1 from slow to fast
				196-205	Shake of Gobo 2 from slow to fast
				206-215	Shake of Gobo 3 from slow to fast
				216-225	Shake of Gobo 4 from slow to fast









				226-235	Shake of Gobo 5 from slow to fast
				236-245	Shake of Gobo 6 from slow to fast
				246-255	Shake of Gobo 7 from slow to fast
11	13	17	Gobo Rotation	000-128	Gobo Indexing(0~540degrees)
				129-188	Rotation (Clockwise From slow to Fast)
				189-195	Stop
				196-255	Rotation (Anti-Clockwise From slow to Fast)
	14	18	Gobo Rotation Fine	000-255	Gobo Rotation in 16 Bit
12	15	19	Effect Wheel	000-020	No
				021-255	Effect Wheel In
13	16	20	Effect Wheel Rotation	000	No
				001-127	Rotation (Clockwise From slow to Fast)
				128-255	Rotation (Anti-Clockwise From slow to Fast)
14	17	21	Prism 1	000-016	Open
				017-127	Prism1
				128-255	Prism2
15	18	22	Prism1 Rotation	000-127	Prism Indexing
				128	Stop
				129-191	Rotation(Clockwise from slow to fast)
				192	Stop
				193-255	Rotation(Anti- Clockwise from slow to fast)
16	19	23	Prism 2	000-016	White
				017-127	Prism3
				128-255	Prism4
17	20	24	Prism2 Rotation	000-127	Prism2 Indexing
				128	Stop
				129-191	Rotation(Clockwise from slow to fast)
				192	Stop
				193-255	Rotation(Anti- Clockwise from slow to fast)
18	21	25	Frost	000-09	No
				010-255	Frost In
19	22	26	Focus	000-255	Linear Focus
	23	27	Focus Fine	000-255	Focus in 16 bit precision
20	24	28	Zoom	000-255	Linear Zoom
	25	29	Zoom Fine	000-255	Zoom in 16 bit precision
21	26	30	Pan	000-255	Pan(0°~540°)
22	27	31	Pan Fine	000-255	Pan in 16 bit
23	28	32	Tilt	000-255	Tilt(0°~270°)
24	29	33	Tilt Fine	000-255	Tilt in 16 bit
	30	34	Pan & Tilt Speeds	000-255	Pan & Tilt Speed from Fast to Slow
25	31	35	Control	000-019	Reserved
				Keep in the DMX range for more than 5S to activate the following functions. If power-off, the following are invalid.	
				020-024	Graphic Display On

				025-029	Graphic Display Off
				030-034	Reserved
				035-039	Lamp ECO Power
				040-044	Lamp Full Power
				045-089	Reserved
				090-094	Pan & Tilt Speed Mode
				095-099	Pan & Tilt Time Mode
				100-129	Reserved
				130-139	Lamp On
				140-149	Pan & Tilt Reset
				150-159	Color System Reset
				160-169	Gobo Wheel Reset
				170-179	Dimmer/Shutter Reset
				180-189	Zoom/Frost/Focus/Prism Reset
				190-199	Reserved
				200-209	Total Reset
				210-229	Reserved
				230-239	Lamp Off
				240-255	Reserved



Note:

1. The projector can't be turned on within 1 minute after the lamp-off.
2. Fan error can cause lamp-off.
3. "Speed Mode" means Pan and Tilt will move from Point A to Point B at their respective maximum speeds."Time Mode" means both Pan and Tilt will arrive at designated point at the same time. It's advised Time Mode be used if the projector runs circles or in oblique lines.

8. SIGNS ON THE TOUCH SCREEN

	Error messages		Option Settings
	Address		Information
	Reset		Service
	Config Settings		Operation Mode
			User Memories

9.ERROR MESSAGES

The system can detect some errors during the reset, if  displayed, touch  to view the error. The error messages are as follows:

Name	Type	Correction
Pan	Timeout/magnet Sensor/Encoder	Check if wiring, positioning parts and motors are normal
Tilt	Timeout/magnet Sensor/Encoder	Check if wiring, positioning parts and motors are normal
Cyan	Timeout	Check if wiring, positioning parts and motors are normal
Yellow	Timeout	Check if wiring, positioning parts and motors are normal
Magenta	Timeout	Check if wiring, positioning parts and motors are normal
CTO	Timeout	Check if wiring, positioning parts and motors are normal
Color Wheel	Timeout	Check if wiring, positioning parts and motors are normal
Fixed gobo wheel	Timeout	Check if wiring, positioning parts and motors are normal
Rot. Gobo Wheel	Timeout	Check if wiring, positioning parts and motors are normal
Rot. Gobo Rotation	Timeout	Check if wiring, positioning parts and motors are normal
Dimmer	Timeout	Check if wiring, positioning parts and motors are normal
Prism 1	Timeout	Check if wiring, positioning parts and motors are normal
Prism 1 Rotation	Timeout	Check if wiring, positioning parts and motors are normal
Prism 2	Timeout	Check if wiring, positioning parts and motors are normal
Prism 2 Rotation	Timeout	Check if wiring, positioning parts and motors are normal
Focus	Timeout	Check if wiring, positioning parts and motors are normal
Zoom	Timeout	Check if wiring, positioning parts and motors are normal
Effect Wheel	Timeout	Check if wiring, positioning parts and motors are normal
Effect wheel Rotation	Timeout	Check if wiring, positioning parts and motors are normal
Fan1 behind lamp	Error	Check if fan and its wiring are normal
Fan2 behind lamp	Error	Check if fan and its wiring are normal
CMY Fan	Error	Check if fan and its wiring are normal
Lamp Fan1	Error	Check if fan and its wiring are normal
Lamp Fan 2	Error	Check if fan and its wiring are normal
Head Fan	Error	Check if fan and its wiring are normal
Pan and Tilt Board	Error	Check signal wire
Driver Board 1	Error	Check signal wire
Driver Board2	Error	Check signal wire
Driver Board3	Error	Check signal wire
Acceleration Sensor	Error	Check signal wire
Lamp on	Timeout	Check if the lamp is damaged
Lamp Life	Timeout Warning	
Lamp Off[Fan Error]	Error	Check if all fans are normal
Lapsed Time	Timeout	
Time IC	Error	
Lapsed time	X days	
Use hours Setting	successfully	

10. TECHNICAL DATA

ELECTRIC PARAMETERS

Input voltages 100V~240V AC, 50/60Hz

Input Power 650W @ 220V

Current at Maximum 8A

Power factor: PF) 0.9

LAMP SPECIFICATIONS

Lamp	PR480L
Color Temperature	6900K
Manufacturers Rated Lamp Life	1500hours

COLORS

1 Color wheel: 12colors+ Open, rainbow effect with bi-directional and variable speeds, Stepping/linear color changing
CMY color mixing system with macros



No.	Code No.	Colors
1	092550001A	Red
2	092550002 A	Light Green
3	092550003 A	Blue
4	092550004 A	Cyan
5	092550005 A	Yellow
6	092550006 A	Magenta
7	092550007 A	Orange
8	092550008 A	Green
9	092550009 A	Dark Blue
10	092550010 A	UV
11	092550011 A	Light Yellow
12	090071258	Dark Yellow

INDEPENDENT CTO SYSTEM

Linear CTO system

FIXED GOBO WHEEL

1 Fixed gobo wheel: 17 gobos +Open

Bi-directionally rotatable, and shakable at variable speeds

Gobo1	Gobo2	Gobo3	Gobo4	Gobo5	Gobo6	Gobo7
Gobo8	Gobo9	Gobo10	Gobo11	Gobo12	Gobo13	Gobo14
Gobo15	Gobo16	Gobo17				

ROTATING GOBO WHEEL

1 Rotating gobo wheel:

7Interchangeable Gobos +Open

Bi-directionally rotatable, and shakable at variable speeds

Gobo1	Gobo 2	Gobo 3	Gobo 4	Gobo 5
Gobo 6	Gobo 7			

Replaceable, Gobo diameter: Φ22.5mm ,Gobo image diameter: Φ12mm

Gobo

PRISM

4 pcs of prisms which can be overlapped (8 facet circular prism+ 4facet linear prism) (9 facet circular prism+ gradient prism) And other optional prisms

EFFECT WHEEL

1 graphic effect wheel, bi-directional rotation with variable speeds and can be overlapped with fixed gobo wheel and rotating gobo wheel

FROST

1pc independent frost filter

FOCUS

DMX linear focus

ZOOM

DMX linear zoom

DIMMER/STROBE

0-100% Linearly adjustable/ Double shutter blades, 0.3~25 F.P.S

HEAD MOVEMENT

Pan 540°, Tilt 270° with auto position correction

BEAM ANGLE

Beam Mode: 0°-- 3°

Spot Mode: 3°-- 40°, Linear Adjustment

Wash Mode: 5°-- 50°, Linear Adjustment

CONTROL

DMX512, 5-pin interfaces(Optional 3-pin)

25channels in short mode, 31channels in standard mode , 35channels in extended mode

Self-test mode

OTHER FUNCTIONS

Adjustable Pan & Tilt speeds

Lamp's and fixture's hours displayed

Modular Structure for easy maintenance

DMX512 wireless receiver (Option)

Optional DMX512 Wireless Transmitter (Option)

HOUSING

High temperature ABS, IP66

NET WEIGHT

37.6 Kg

SIZES

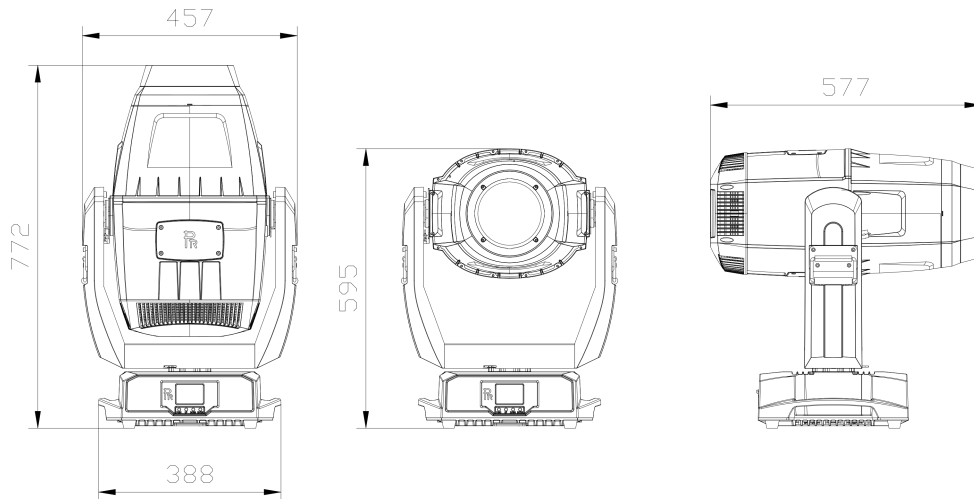

Base installation and its sizes: (unit: mm)

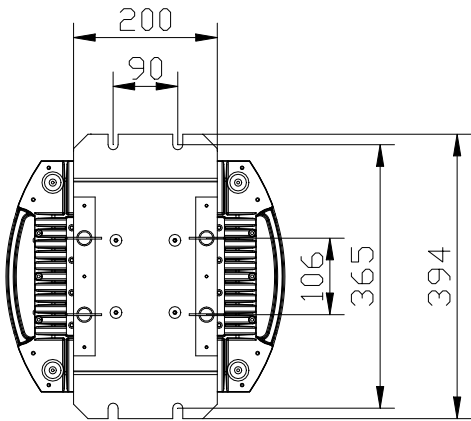

LIGHT OUTPUT

40° Lux	0	9185	2296	1021	574	367	255
3° Lux	0	1526861	381715	169651	95429	61074	42413

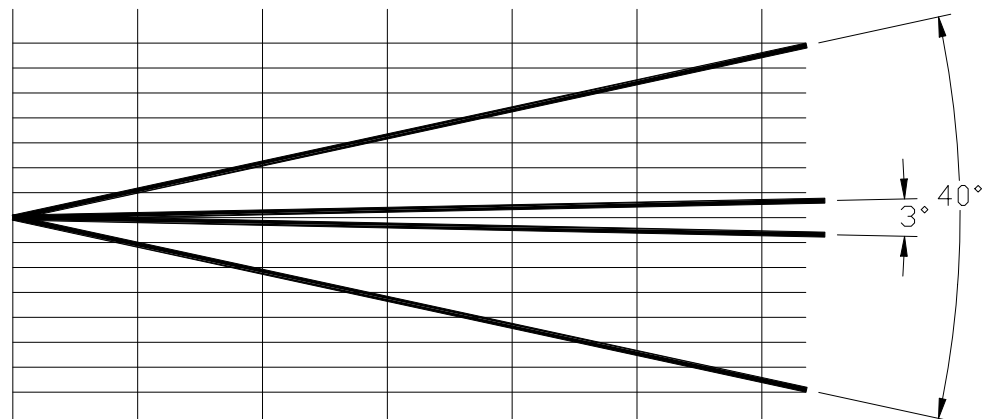

DISTANCE (m)	0	5	10	15	20	25	30
3° DIAMETER (m)	0	ø0.27	ø0.54	ø0.81	ø1.08	ø1.35	ø1.62
40° DIAMETER (m)	0	ø3.59	ø7.18	ø10.76	ø14.35	ø17.94	ø21.53

11. CIRCUIT DIAGRAM

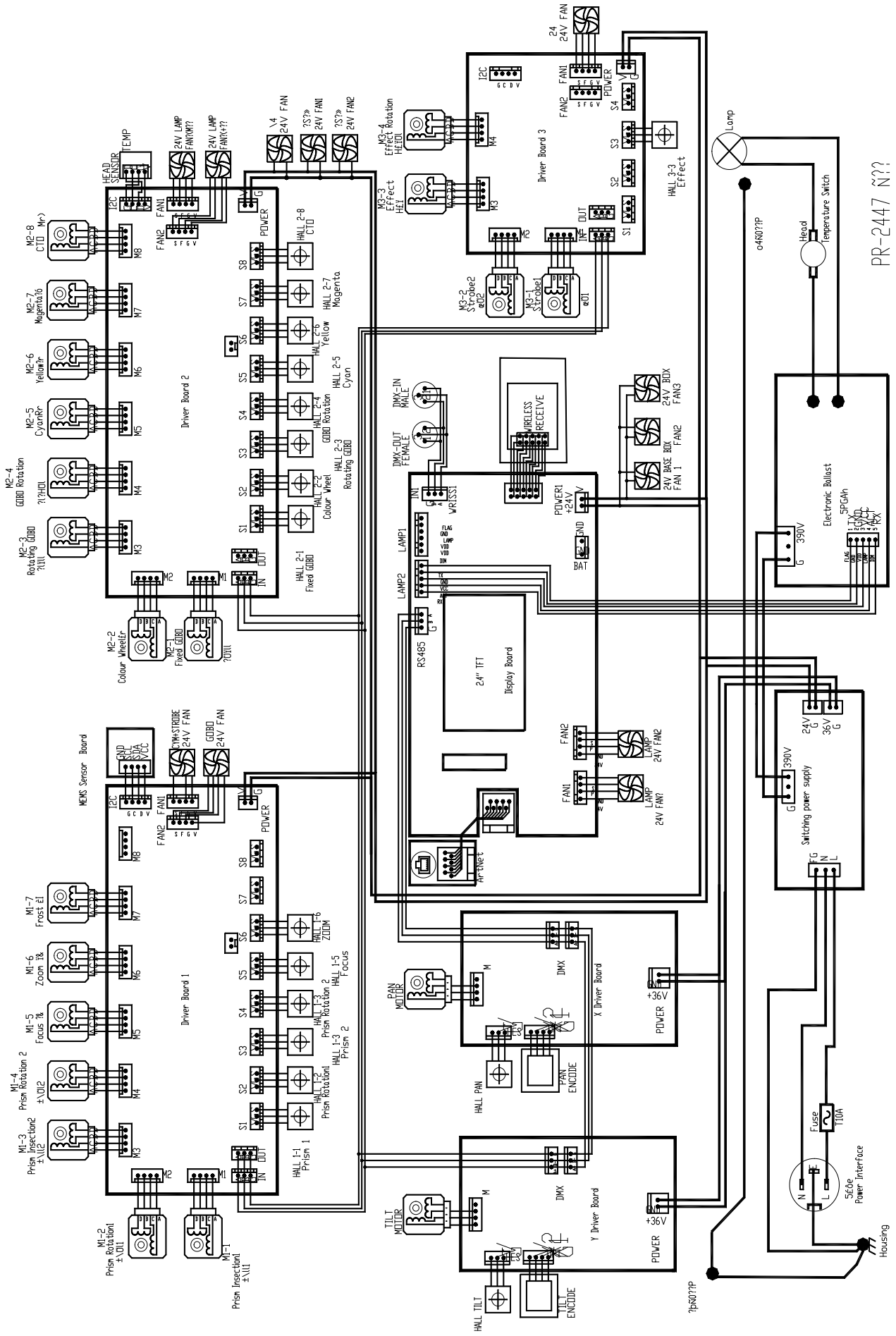

12. COMPONENT ORDER CODES

NAME	PART NO.	QTY.	REMARKS
STEPPER MOTOR	030040284	1	
STEPPER MOTOR	030040242A	1	
STEPPER MOTOR	030040277	2	
STEPPER MOTOR	030040121A	2	
STEPPER MOTOR	030040278	1	
STEPPER MOTOR	030040275	1	
STEPPER MOTOR	030040279	1	
STEPPER MOTOR	030040213B	2	
STEPPER MOTOR	030040246B	1	
STEPPER MOTOR	030040254A	4	
STEPPER MOTOR	030040221C	3	
STEPPER MOTOR	030040224C	1	
STEPPER MOTOR	030040257A	1	
5R FAN	030060094A	2	
PWM SPEED ADJUSTING FAN	030060117	5	
FAN	030060075	4	
4 WIRE WATERPROOF FAN	030060116	1	
FAN	030060113	1	
BALLAST	040070139	1	
LAMP	100070051	1	
ROTATING GOBO WHEEL ACCESSORY	120111036	1	
COLOR WHEEL ACCESSORY	120110973	1	
FIXED GOBO WHEEL ACCESSORY	120111035	1	
SWITCHING POWER SUPPLY	192010223	1	

Appendix: Advice on the Use of Platinum Lamps

Dear Client,

The platinum lamps favored by the lighting sector have high color temperature, high brightness, high CRI, pure light beam and other advantages. For their use, some advice is offered for your reference:

1. After lamp on, it shouldn't be turned off in a very short while. Frequent lamp on and offs will wear out its electrodes, thus resulting in lower brightness and lumen decrease.
2. It's advised to turn off the lamp by controller, but not by shutting off the mains power which can stop the cooling system from working immediately, shortening the lamp's lifespan and may cause short circuit between the electrodes.
3. In case of emergent blackout, do not strike the lamp immediately after mains power recovers. The lamp can be re-stricken successfully 10-15minutes after lamp-off while the fixture's temperature is lower than the start one.
4. The metal vapor in the lamp can cause aging and harm to the place of the burner where it accumulates after the head is fixed at certain position for a long time, resulting in whitening of the burner glass, cracking in it and even damage, thus shortening of its life. It's advised to let the head move in slow speed after shutters closed while the fixture is idle to avoid the head at fixed angle for a long time.

Thank you for your trust and patience.

PR LIGHTING LTD.

1582 Xingye Avenue, Nancun Panyu
Guangzhou, 511442 China
TEL: +86-20-3995 2888

PR lighting will try its best to offer accurate and overall information about a product's technical data. Any changes won't be notified if necessary. Patented Products.
Counterfeiting Will be Prosecuted!

P/N: 320020864B
Version: 20260319